



User Manual

Contents



Log splitter

(AUS)



- Explanation of Symbols07
- Introduction09
- Layout10
- Scope of delivery10
- Intended use11
- Safety regulations12
- Setup18
- Before starting the equipment18
- Operation19
- Cleaning20
- Maintenance and repair21
- Technical Data23
- Storage23
- Transport23
- Electrical connection24
- Disposal and recycling25
- Troubleshooting26
- Warranty Details29
- Repair and Refurbished Goods or Parts Notice30

ALDI guarantees that our exclusive brand products are developed to our stringent quality specifications. If you are not entirely satisfied with this product, please return it to your nearest ALDI store within 60 days from the date of purchase for a full refund or replacement, or take advantage of our after sales support by calling the supplier's Customer Service Hotline.

Made in China
 GARDENLINE® is a registered trademark of ALDI Stores
 DISTRIBUTED BY:
 ALDI STORES
 1 SARGENTS ROAD
 MINCHINBURY NSW 2770
 www.aldi.com.au

AFTER SALES SUPPORT



☎ (AUS) 1300 855 831 ✉ support@scheppach.com.au

MODEL: HL650o PRODUCT CODE: 52626 04/2018



Vers.No. 171002

Original instructions



Explanation of Symbols

	<p>Read the operating instructions carefully!</p>
	<p>Wear working gloves!</p>
	<p>Wear safety glasses!</p>
	<p>Wear working shoes!</p>
	<p>Do not remove or modify protection and safety devices.</p>
	<p>Dispose of waste oil correctly (waste oil collection point on site). Do not dump waste oil in the ground or mix it with waste.</p>
	<p>Do not reach into the machine without any protection!</p>

Explanation of Symbols



Caution! Moving parts!



Danger of bruising and injury from sharp edges; never touch danger areas when the cleaver is moving.
Risk of injury!



Disconnect the mains plug prior to the repair, cleaning, and maintenance of the splitter!

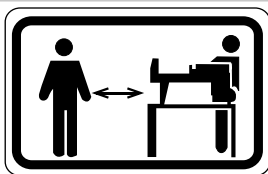

Only the operator is allowed in the work area of the machine. Keep other people and animals (minimum distance 5 m) at a distance.

I. INTRODUCTION

Congratulations on choosing to buy a GARDENLINE® product.

All products brought to you by GARDENLINE® are manufactured to the highest standards of performance and safety, and as part of our philosophy of customer service and satisfaction, are backed by our comprehensive 5 Years Warranty. We hope you will enjoy using your purchase for many years to come.

Note:

According to the applicable product liability law the manufacturer of this device is not liable for damages which arise on or in connection with this device in case of:

- improper handling,
- non-compliance with the instructions for use,
- repairs by third party, non-authorized skilled workers,
- installation and replacement of non-original spare parts,
- improper use.
- failures of the electrical system due to the non-compliance with the electrical specifications and regulations.

Recommendations:

Read the entire text of the operating instructions prior to the assembly and operation of the device.

These operating instructions are intended to make it easier for you to get familiar with your device and utilise its intended possibilities of use.

The operating instructions contain important notes on how to work safely, properly and economically with your machine and how to avoid dangers, save repair costs, reduce downtime, and increase the reliability and working life of the machine.

In addition to the safety regulations contained herein, you must in any case comply with the applicable regulations of your country with respect to the operation of the machine.

Keep the operating instructions in a clear plastic folder to protect them from dirt and humidity; store them near the machine. The instructions should be read and carefully understood by each operator prior to using the machine. Only persons who have been trained in the use of the machine and are aware of the related dangers and risks should be allowed use the machine. The local required minimum age must be met.

In addition to the safety notes contained in these operating instructions and any specific regulations in your country, the generally recognised technical rules for the operation of identically constructed machines must be observed.

II. LAYOUT (Fig. 1)

- 1 Oil Tank
- 2 Log Pusher
- 3 Work Table
- 4 Splitting Wedge
- 5 Lift Handle
- 6 Support Leg
- 7 Switch
- 8 Motor
- 9 Transport Wheel
- 10 Hydraulic Lever
- 11 Oil Drain Bolt / Dipstick
- 12 Venting Screw
- 13 Hoist Limiting Ring

III. SCOPE OF DELIVERY

Log Splitter	(1x)
Instruction Manual	(1x)
Warranty Card & Details	(1x)

- Open the packaging and take out the equipment with care.
- Remove the packaging material.
- Check that all listed contents are present.
- Inspect the equipment and parts for any damage. Please contact the helpline if anything is missing.
- If possible, keep the packaging until the end of the guarantee period.
- Read the operating instructions fully to familiarise yourself with the tool prior to using it.
- Only use original accessories and spare parts. Spare parts are available by contacting the helpline.
- Specify the part numbers when you contact the helpline.

⚠ ATTENTION!

The device and packaging materials are not toys!

Children must not be allowed to play with plastic bags, film and small parts!

There is a risk of swallowing and suffocation!

IV. INTENDED USE

The hydraulic log splitter may only be used in a horizontal position.

Wood may only be split in a horizontal position along the fibre.

The maximum split wood length is 52 cm.

1. The equipment is to be used only for its prescribed purpose. Any other use is deemed to be a case of misuse.
2. The user / operator and not the manufacturer will be liable for any damage or injuries of any kind caused as a result of this.
3. To use the equipment properly you must also observe the safety information, the assembly instructions and the operating instructions to be found in this manual.
4. All persons who use and service the equipment have to be acquainted with this manual and must be informed about the equipment's potential hazards.
5. It is also imperative to observe the accident prevention regulations in force in your area.
6. The same applies for the general rules of health and safety at work.
7. The manufacturer will not be liable for any changes made to the equipment nor for any damage resulting from such changes.

Even when the equipment is used as prescribed it is still impossible to eliminate certain residual risk factors. The following hazards may arise in connection with the machine's construction and design:

- Dry and dried-up wood may jump up when being split and injure the face of the operator. Adequate protective clothes to be worn!
- Wooden pieces produced during splitting may fall down and injure legs of the operator.
- When splitting wood, parts of body may be crushed or separated due to hydraulic knife lowering.
- There is a risk of branchy wood getting stuck when being split. Please be advised that wood being separated is under heavy pressure and your fingers may get squeezed in the gap.
- Caution! Pieces of wood cut at the right angle to be split only! Diagonally cut pieces of wood may slip when cutting! This may cause personal injury or damage to the splitter knife especially when using the gap extension by Splitting Wedge!

Please note that our equipment has not been designed for use in commercial, trade or industrial applications. Our warranty will be voided if the equipment is used in commercial, trade or industrial businesses or for equivalent purposes.

V. SAFETY REGULATIONS

These operating instructions provide places concerning your safety which are marked with this indication: ⚠

⚠ GENERAL SAFETY NOTES

You must read the complete instruction and maintenance manual before you use the machine.

- You must wear safety shoes at all times to protect yourself against the risk of falling trunks.
- You must wear work gloves at all times to protect your hands from chips and splinters generated while you work.
- You must wear safety goggles or a visor to protect yourself from chips and splinters generated while you work.
- It is prohibited to remove or modify any protective equipment or safety equipment.
- No one apart from the operator is permitted to stand within the working radius of the machine. No other person or animal is permitted to be within a radius of 5 meters of the machine.
- It is prohibited to allow used oil to be discharged to the environment. The oil must be disposed of in accordance with the regulations of the country in which the machine is used.

⚠ Risk of hands being cut or crushed

Never touch any dangerous areas while the Splitting Wedge is moving.

⚠ WARNING!

Keep an eye on the movement of the log pusher at all times.

⚠ WARNING!

Never attempt to remove a trunk which has got stuck on the Splitting Wedge by hand.

⚠ WARNING!

Always unplug the power plug prior to starting any of the maintenance work described in this manual.

⚠ WARNING!

The voltage must be the same as the voltage specified on the rating plate.

Keep these regulations in a safe place!

1. WORK AREA

- Keep your work area clean and tidy. Disorder and insufficiently illuminated work areas can lead to accidents.
- Do not use this tool in a potentially explosive environment containing combustible liquids, gases or dust. Electric tools generate sparks, which can in turn ignite dust or vapors.
- Keep children and other persons away from the electric tool while it is being used. Allowing yourself to get distracted can cause you to lose control of the tool.

2. ELECTRICAL SAFETY

Attention! The following basic safety measures must be observed when using electric tools for protection against electric shock, and the risk of injury and fire. Read all these notices before using the electric tool and keep the safety instructions for later reference.

- The tools connector plug must be able to fit into the socket outlet. Do not modify the plug in any way! Do not use adapter plugs in conjunction with electrically grounded tools. Unmodified plugs and matching socket outlets reduce the risk of an electric shock.
- Avoid touching grounded surfaces, such as those of pipes/tubes, heaters, cookers and refrigerators. There is an increased risk of getting an electric shock if you are electrically grounded.
- Keep the tool away from rain and moisture/wet conditions. Penetration of water into an electric tool increases the risk of an electric shock.
- Do not use the cable to carry the tool, hang it up or pull the plug out of the socket. Keep the cable away from sources of heat, oil, sharp edges and moving tool parts. Damaged or tangled cable increases the risk of an electric shock.
- If you intend to use an electric tool outdoors, ensure that you only use extension cable that is approved for outdoor applications. Using extension cable that is approved for outdoor applications reduces the risk of an electric shock.
- Connect the electric tool to the mains power supply (230 - 240 V~, 50Hz) via a socket-outlet with earthing contact. We recommend that you fit a residual-current protection device with a maximum nominal tripping current of 30 mA. Seek the advice of your electrician.

3. PERSONAL SAFETY

- Be alert, work conscientiously and exercise appropriate caution when using the electric tool. Do not use the tool if you are tired or are under the influence of drugs/medication or alcohol. One moment of carelessness or lack of attention when using the electric tool can cause serious bodily injury!
- Always wear personal protective equipment (PPE), including safety goggles. Wearing personal protective equipment such as a dust mask, non-slip footwear, protective headgear and ear muffs (depending upon the type of electric tool and the particular application) reduces the risk of sustaining injury.
 - » Wear ear-muffs. The impact of noise can cause damage to hearing.
 - » Wear safety goggles. Sparks generated during working or splinters, chips and dust emitted by the device can cause loss of sight.
- Physically touching the switch with your finger when carrying the tool or connecting the tool to the power supply switched on can lead to accidents.
- Remove adjusting tools/wrench(es) prior to switching on the power tool. A tool or wrench that is positioned inside a rotating power tool part can cause injury.

- Do not overestimate your abilities. Make sure you stand squarely and keep your balance at all times. This way, you will be able to have better control over the tool in unexpected situations.
- Wear suitable clothes. Never wear loose fitting clothes or jewelry. Keep hair, clothes and gloves away from moving parts. Loose clothing, dangling jewelry and long hair can be caught by moving parts.

4. CAREFUL HANDLING AND USE OF ELECTRIC TOOLS

- Do not overload your tool. Only use suitable electric tools to perform your work. Using the right electric tool allows you to work better and safer within the tool's quoted capacity range.
- Do not use an electric tool whose switch is defective. An electric tool that no longer can be switched on or off is dangerous and must be repaired.
- Always pull the plug out of the socket outlet before making any adjustments. Exchange accessory parts or put away the tool. This precaution eliminates the possibility of inadvertently starting the tool.
- When not in use, store electric tools out of the reach of children. Do not allow those persons to use this tool who are unfamiliar with it or who have not read these instructions. Electric tools are dangerous when they are used by inexperienced persons.
- Take good care of your tool. Check that moving parts properly function and do not jam, that parts are not broken off or damaged in any way and that the tool can be used to its full capacity. Have damaged parts repaired prior to using the tool. The cause of many accidents can be traced back to poorly maintained electric tools.
- Use electric tools and plug-in tools, etc. in compliance with these instructions and in the manner that is prescribed for the model at hand. In so doing, pay due attention to working conditions and the job to be performed. Using electric tools for applications other than those intended can lead to dangerous situations.
- If the power cable of the electric tool is damaged, it must be replaced by a specially prepared connection lead which can be obtained from the customer service center.

5. SERVICE

Have your tool repaired only by authorized specialists using original replacement parts. This will ensure that your tool remains safe to use.

SPECIAL SAFETY INSTRUCTIONS FOR THE WOOD SPLITTER

⚠ DANGER! Keep clear of moving parts! Never reach into the splitting zone.

⚠ WARNING!

The use of this powerful machine can give rise to special types of danger. Take particular care to protect both yourself and all other persons in the vicinity. You should comply with basic precautionary measures at all times in order to minimise the risk of injuries and danger.

The machine must never be operated by more than one operator.

- Never attempt to split any trunks which are larger than the recommended trunk capacity.
- The trunks must be free of any nails or wire which may be flung out or might damage the machine during operation.
- The trunks must be cut flat at the ends and have had all branches removed from them.
- The wood must always be split along the direction of the grain. Never insert the piece of wood crosswise to the splitter and then attempt to split it as this could damage the splitter
- The operator must operate the machine controls with both hands and must not use any other kind of device as a substitute for the controls.
- The machine may be operated only by adults who have read the operating instructions prior to starting operation. No one is permitted to use the machine without reading the manual first.
- Never attempt to split two trunks in a single operation as this may cause pieces of wood to be flung out, which is dangerous.
- Never add more wood or replace a piece of wood while the machine is in the middle of an operation as this would be extremely dangerous.
- All persons and animals must be kept at least 5 meters from the machine while it is working.
- Never modify the protective equipment on the wood splitter or carry out any work without such equipment attached.
- Never attempt to force the wood splitter to split excessively hard pieces of wood under cylinder pressure for more than 5 seconds. Overheated oil under pressure may cause damage to the machine. Stop the machine, turn the trunk through 90° and then try to split it again. If the wood still fails to split this means that it is too hard for the capacity of the machine and must be removed to avoid damaging the wood splitter.
- Never leave the machine unattended while running. Stop the machine and unplug the power plug whenever you are not using it.
- Never use the machine near natural gas, petrol channels or other inflammable materials.
- Never open the control box or the motor cover. If necessary, contact a qualified electrician.

AFTER SALES SUPPORT

15

- Make sure that the machine and the cable never come into contact with water. Handle the power cable with care and never pull or tug it with a jolt to unplug it. Keep all cables away from excessive heat, oil and sharp-edged objects.
- Please take note of the temperature conditions whilst you work. Extremely low and extremely high ambient temperatures may cause malfunctions.
- Before using the wood splitter for the first time, users should be given practical training by an experienced operator and should initially work with it under supervision.

Before starting work check the following:

- Do all the functions of the tool function correctly?
- Does all the safety equipment function correctly?
- Can the tool be switched off correctly?
- Is the tool adjusted correctly (truck support, trunk holding plates, splitter height)?

Keep the working area free of obstructions (for example pieces of wood) whilst working.

SPECIAL WARNINGS RELATING TO THE USE OF THE WOOD SPLITTER

Special types of danger can arise during the use of this powerful machine. Take particular care to protect both yourself and all other persons in the vicinity.

Hydraulic system

Never use the machine if there is ever any danger from hydraulic fluid. Check for leaks in the hydraulic system every time before you start using the machine. Check that the machine and your work area are clean and free of any patches of oil.

Hydraulic fluid may be the cause of danger because it can cause you to slip and fall, may make your hands slip while operating the machine or may cause a fire.

Electrical safety

- Never use the machine if there is any risk of an electrical hazard.
- Never use an electrical device in moist conditions.
- Never use this machine with an unsuitable cable or extension cable. Never use this machine if you are not connected to a properly earthed connection which provides the power required as specified on the label and is protected by a 16 amp fuse.

Mechanical hazards

Wood splitting is associated with particular mechanical hazards.

- Never use this machine if you are not wearing proper safety gloves, shoes with steel caps and certified eye protection.
- Be cautious of splinters generated while working; avoid stab-like injuries and the possibility of the machine seizing up.

- Never attempt to split any trunks which are either too long or too small and do not fit in the machine properly.
- Never attempt to split any trunks which contain nails, wire or any other objects.
- Clear up while you work; collections of split wood and wood chips can make your work area dangerous. Never continue working if your work area is full to the extent that you could slip, trip or fall over.
- Keep onlookers well away from the machine and never permit unauthorized persons to operate the machine.

ACCIDENT PREVENTION STANDARDS

- 1) The machine may only be operated by people who are well familiar with the contents of this manual.
- 2) Before use, check the intactness and perfect function of the safety devices.
- 3) Before use, make yourself also familiar with the control mechanisms of the machine, following the operating instructions.
- 4) The capacity of the machine indicated may not be surpassed. In no way may the machine be used for any other purposes than splitting firewood.
- 5) In agreement with your country's laws, the personnel must wear adequate, close-fitting working clothes. Jewelry like watches, rings and necklaces must be taken off. Long hair must be protected by a hair net.
- 6) The work place should always be tidy and clean. Tools, accessories and wrenches should lie within reach.
- 7) During cleaning or maintenance work, the machine may never be connected to the mains.
- 8) **It is strictly prohibited** to use the machine with the safety devices removed or switched off.
- 9) **It is strictly prohibited** to remove or modify the safety devices.
- 10) Before undertaking any maintenance or adjusting work, carefully read and understand the present operating instructions.
- 11) For a good performance of the machine as well as for safety reasons, the plan given herein must be adhered to.
- 12) In order to prevent accidents, the safety labels must always be kept clean and legible, and they must be strictly observed. Any missing labels must be reordered from the manufacturer and be attached to the correct place.
- 13) In case of fire, only fire-fighting powder may be used. Water is not allowed to extinct the fire because of the risk of short circuit.
- 14) If the fire cannot be extinct immediately, pay attention to leaking liquids.
- 15) In case of a longer fire, the oil tank or the pressure lines can explode. Be careful not to get

⚠️ REMAINING HAZARDS

The machine has been built using modern technology in accordance with recognized safety rules. Some remaining hazards, however, may still exist.

- The splitting tool can cause injuries to fingers and hands if the wood is incorrectly guided or supported.
- Thrown pieces can lead to injury if the work piece is not correctly placed or held.
- Injury through electric current if incorrect electric connection leads are used.
- Danger due to particular properties of the log (branches, irregular shape etc)

Even when all safety measures are taken, some remaining hazards which are not yet evident may still be present.

Remaining hazards can be minimized by following the safety instructions as well as the instructions in the chapter Authorized use and in the entire operating manual.

VI. SETUP

Prepare the workplace where the machine is to be placed.

Ensure sufficient room to allow safe work without malfunctions.

The machine is designed to operate on a level surface and must be placed securely on stable plain ground.

VII. BEFORE STARTING THE EQUIPMENT

Make sure the machine is completely and expertly assembled.

Check before every use:

- The connection cables for any defective spots (cracks, cuts etc.).
- The machine for any possible damage.
- The firm seat of all bolts.
- The hydraulic system for leakage.
- The oil level.

VENTING, FIG. 7 / 8

⚠️ ATTENTION!

Before working with the log splitter, vent the hydraulic system.

- Release the Venting Screw (12) by a few revolutions so the air can escape from the oil tank.
- Leave the Venting Screw (12) open during the operation.
- Before you move the log splitter, close the Venting Screw (12) again in order not to lose any oil.

If the hydraulic system is not vented, the enclosed air will damage the gaskets and with it the complete log splitter.

VIII. OPERATION

Only split plain cut log.

SWITCHING "ON" AND "OFF"

⚠ ATTENTION!

Loosen the Venting Screw (12) two revolutions, before starting work.
Close before transport. FIG. 7 / 8

1. Place the splitting material in horizontal direction to the Work Table (3).
2. Your machine is equipped with Two-hands Control System that requires operation by both hands of the user
 - left hand controls the Hydraulic Lever (10) while
 - right hand controls the Switch (7).
3. Simultaneously push the Hydraulic Lever (10) and the Switch (7) to start splitting action.
4. Wait until the splitting process is ended and release then the Hydraulic Lever (10) and the Switch (7). The Splitting wedge (4) is returned to the home position.
5. Afterwards you can remove splitting material.

The log splitter will freeze upon absence of either hand.

If you release the Switch (7) the Motor (8) stops.

The release of all hands means that the Log Pusher (2) will be retracted.

⚠ ATTENTION!

Check the function of the "ON-/OFF" unit before every use by switching on and off once, as described above (Switching "ON" and "OFF").

Never force your machine for more than 5 seconds by keeping pressure on it to split excessively hard wood. After this time interval, the oil under pressure will be overheated and the machine could be damaged.

For such an extremely hard log, rotate it by 90° to see whether it can be split in a different direction. In any case, if you are not able to split the log, this means that its hardness exceeds the capacity of the machine and thus should be discarded to protect the log splitter.

END OF WORK

- Release hands from Two-hands Control System.
- Pull the power plug.
- Close the venting cap.
- Observe the general maintenance instructions.

AFTER SALES SUPPORT

HOIST LIMITING, FIG. 1

For short splitting material it is possible to shorten the return movement of the Splitting Wedge (7). To do so, press the Hydraulics Lever (10) and the Switch (7) and let the Log Pusher (2) move just in front of the splitting material. Release the Switch (7) now and mount the Hoist Limiting Ring (13) to the housing and tighten it. Afterwards you can release the Hydraulics Lever (10). The Log Pusher (2) will now be resting in the selected position.

WRONGLY PLACED LOG, FIG. 2

Always set logs firmly on the work table. Make sure logs will not twist, rock or slip while being split. Do not force the blade by splitting logs on the upper part. This will break the blade or damage the machine. Do not attempt to split 2 pieces of logs at the same time. One of them may fly up and hit you.

JAMMED LOG, FIG. 3 / 4

Do not try to knock the jammed log off. Knocking about will damage the machine or may launch the log and cause accident.

1. Release both controls.
2. After the Log Pusher (2) moves back and completely stops at its starting position, insert a wedge wood under the jammed log as shown in the figure.
3. Start the log splitter to push the wedge wood under the jammed one.
4. Repeat above procedure with sharper slope wedge woods until the log is completely freed.

IX. CLEANING**⚠ IMPORTANT!**

Always pull out plug each time before carrying out any cleaning.

Keep all safety devices, air vents and the motor housing free of dirt and dust as far as possible.

Wipe the equipment with a clean cloth or blow it with compressed air at low pressure - **Attention! Wear safety glasses for this work.**

We recommend that you clean the device immediately each time you have finished using it.

Clean the equipment regularly with a moist cloth and some soft soap. Do not use cleaning agents or solvents - these could attack the plastic parts of the equipment. Ensure that no water can seep into the device.

X. MAINTENANCE AND REPAIR

Carry out refitting, setting and cleaning work only when the motor is switched off. Pull the power plug.

An experienced worker can carry out minor repairs on the machine alone.

Repair and maintenance work on the electrical system may only be carried out by a qualified electrician.

All protective and safety devices must be reattached immediately after completed repair and maintenance work.

We recommend:

- The Splitting Wedge is a wearing part that needs to be sharpened or replaced after wear.
- The combined gripping and controlling device must remain smooth running. Lubricate with a few drops of oil when necessary.
- Keep Splitting Wedge drive clean of dirt, wood shavings, bark, etc.
- Lubricate slide rails with grease.

SHARPEN THE SPLITTING WEDGE FIG. 1

If the Splitting Wedge (1) is worn out, use an angle grinder and sharpen the edges. If you are not confident contact a professional repair person.

OIL CHANGE FIG. 5 - 7

The hydraulic system is a closed system with oil tank, oil pump and control valve. The system is complete when the machine is delivered, and may not be changed or manipulated.

Check hydraulic connections and fittings regularly for air tightness.

Tighten when necessary.

The oil tank has been filled with high quality oil at the factory.

Replace hydraulic oil after 150 hours of use.

1. Make sure all moving parts stop and the log splitter is unplugged.
2. Unscrew Oil Drain Bolt / Dipstick (11) to remove it.
3. Tip the log splitter on the support leg end as shown in fig. 5 over a 4 litre capacity container to drain the hydraulic oil. Recycle carefully!
4. Tip your machine on the motor end as shown in Fig. 6 to refill about 3.5 L fresh oil.
5. Clean the surface of the dipstick on the Oil Drain Bolt (11) and put it back into the oil tank while keeping the log splitter vertical.
Make sure the level of the refilled oil is just between 2 grooves around the dipstick.
6. Clean the Oil Drain Bolt (11) before threading it back. Make sure it is tightened to avoid leakage before placing the log splitter horizontally. Afterwards, run the

machine through several splitting cycles without logs on the work table.
Regularly check the oil level.
Too low an oil level damages the oil pump.
Regularly check the hydraulic connections and bolts for tightness.
Re-tighten if necessary.

Upon low oil level, oil refilling is required.
Dispose of the used oil in a correct manner at a public collection facility.
It is prohibited to drop old oil on the ground or to mix it with waste.
We recommend the following hydraulic oils:

- Aral Vitam gf 22
- BP Energol HLP-HM 22
- Mobil DTE 11
- Shell Tellus 22

or oils of same quality.

Do not use any other types of oil as they would influence the function of the hydraulic cylinder.

Before undertaking any maintenance or checking work, the working area must be cleaned. Keep the necessary tools within the reach of your hand.

The intervals mentioned herein are based on normal conditions of use. An excessive use of the machine shortens the intervals accordingly.

Clean the panels, screens and control levers with a soft cloth. The cloth should be dry or slightly humid with a neutral cleaning agent. Do not use any solvents like alcohol or benzene as they could damage the surfaces.

Store oil and grease outside the reach of unauthorized personnel. Strictly follow the instructions on the bins. Avoid direct contact with the skin. Rinse well after use.

XI. TECHNICAL DATA

Dimensions L x W x H mm	950 x 270 x 500
Wood ø mm	50-250
Wood length mm	250-520
Weight kg	45
Motor	
Motor V/Hz	220 - 240~/50
Input W	2200
Rating	S3/25%
Splitting Power t	max. 6.5
Cylinder rise mm	375
Cylinder speed (fast fwd.) cm/sec	3.1
Cylinder speed (return) cm/sec	4.6
Hydraulic fluid capacity L	3.5
Operating pressure bar	220
Motor speed rpm	2800

Subject to technical changes!

XII. STORAGE

Store the device and its accessories in a dark, dry and frost-proof place that is inaccessible to children. The optimum storage temperature is between 5 and 30°C.

Store the electrical tool in its original packaging.

Cover the electrical tool in order to protect it from dust and moisture.

Store the operating manual with the electrical tool.

XIII. TRANSPORT

Before moving your machine, make sure the Venting Screw (12) is tightened to avoid oil leaking from this point.

TRANSPORT:

To remove the machine packaging from the pallet, two persons will be required.

The machine may be transported while held in a diagonal position. Use the hand grip and pull gently while the machine stands on its wheels.

XIV. ELECTRICAL CONNECTION

The electrical motor installed is connected and ready for operation. The connection complies with the applicable Australian standards. The customer's mains connection as well as the extension cable used must also comply with these regulations.

Important information

In the event of an overloading the motor will switch itself off. After a cool-down period (time varies) the motor can be switched back on again.

Damaged electrical connection cable

The insulation on electrical connection cables is often damaged.

This may have the following causes:

- Passage points, where connection cables are passed through windows or doors.
- Kinks where the connection cable has been improperly fastened or routed.
- Places where the connection cables have been cut due to being driven over.
- Insulation damage due to being ripped out of the wall outlet.
- Cracks due to the insulation ageing.

Such damaged electrical connection cables must not be used and are life-threatening due to the insulation damage. Check the electrical connection cables for damage regularly.

Make sure that the power is switched off before inspecting the cable. Electrical connection cables must comply with the applicable Australian standards and must be correctly marked. Only use connection cables with the marking "H05VV-F". Replacement cables can only be fitted by an approved and certified electrician. If you are in any doubt please contact the help line at the foot of this page.

AC motor

- The mains voltage must be 230 - 240 V~
- Extension lines up to a length of 25 m must have a minimum cross section of 1.5 mm², lines with a length exceeding 25 m must have a minimum cross section of 2.5 mm².

Connections and repairs of electrical equipment may only be carried out by an electrician.

Please provide the following information in the event of any enquiries:

- Type of current for the motor
- Machine data - type plate
- Machine data - type plate

XV. DISPOSAL AND RECYCLING

The equipment is supplied in packaging to prevent it from being damaged in transit. The raw materials in this packaging can be reused or recycled. The equipment and its accessories are made of various types of material, such as metal and plastic. Defective components must be disposed of as special waste. Ask your dealer or your local council.

Dismounting and disposal

The machine does not include any components harmful to health or environment. All the materials can be recycled or decomposed the normal way. Charge specialized personnel with the disposal that is familiar with the possible risks and with the present manual.

When the machine is not used any more and is to be disposed of, proceed as follows:

- Cut off the electric power supply.
- Remove all electric cables and bring them to a specialized public collection facility following your country's regulations.
- Empty the oil tank, fill the oil in a tight bin and bring it to a specialized public collection facility following your country's regulations.
- Take all other machine parts to a scrap collection facility following your country's regulations.

Be sure every machine part is disposed of following your country's regulations.

XVI. TROUBLESHOOTING

The table below contains a list of fault symptoms and explains what you can do to remedy the problem if your equipment fails to work properly. If the problem still persists after working through the list, please contact your nearest service workshop.

⚠ IMPORTANT!

Hint in case of sending the equipment to a service station:

Due to security reasons please see to it that the equipment is sent back free of oil and petrol!

Problem	Possible Cause	Remedy
Motor stops starting	Overload protection device disengaged to protect the log splitter from being damaged	Contact a qualified Electrician
Fails to split logs	a) Log is improperly positioned b) Size of log exceeds the capacity of the machine c) Splitting Wedge cutting edge is blunt d) Oil leaks	a) Refer to "operation" section to perfect log loading b) Reduce log size before operating c) Sharpen cutting edge d) Locate leak(s) and contact your dealer
Log pusher moves jerkily, making unfamiliar noise or vibrating a lot	Lack of hydraulic oil and excessive air in the hydraulic system	Check oil level for possible refilling Contact your dealer
Oil leaks around the cylinder ram or from other points	a) Air sealed in hydraulic system while operating b) Bleed screw is not tightened before moving the log splitter c) Oil drain bolt is not tight d) Hydraulic control valve assembly and/or seal(s) worn	a) Loosen bleed screw by some rotations before operating the log splitter b) Tighten bleed screw up before moving the log splitter c) Tighten the oil drain bolt d) Contact your dealer

Maintenance and repairs

All servicing jobs must be executed by specialized personal under strict observation of the present operating instructions. Before every work, every possible caution must be taken: Switch off the motor, disconnect the power supply (pull the plug, if necessary). Attach a board to the machine explaining the reason for being out of order: "Machine out of order due to servicing work: Unauthorized people must not come close to the machine or switch it on."



LOG SPLITTER

Warranty Details



REGISTER YOUR PURCHASE AT www.aldi.com.au/en/about-aldi/product-registration/ TO KEEP UP-TO-DATE WITH IMPORTANT PRODUCT INFORMATION

The product is guaranteed to be free from defects in workmanship and parts for a period of 60 months from the date of purchase. Defects that occur within this warranty period, under normal use and care, will be repaired, replaced or refunded at our discretion.

The benefits conferred by this warranty are in addition to all rights and remedies in respect of the product that the consumer has under the Competition and Consumer Act 2010 and similar state and territory laws.

Our goods come with guarantees that cannot be excluded under the Australian Consumer Law. You are entitled to a replacement or refund for a major failure and for compensation for any other reasonably foreseeable loss or damage. You are also entitled to have the goods repaired or replaced if the goods fail to be of acceptable quality and the failure does not amount to a major failure.

AFTER SALES SUPPORT

  1300 855 831

 support@scheppach.com.au

MODEL: HL650o PRODUCT CODE: 52626 04/2018





LOG SPLITTER

Repair and Refurbished Goods or Parts Notice

Unfortunately, from time to time, faulty products are manufactured which need to be returned to the Supplier for repair.

Please be aware that if your product is capable of retaining user-generated data (such as files stored on a computer hard drive, telephone numbers stored on a mobile telephone, songs stored on a portable media player, games saved on a games console or files stored on a USB memory stick) during the process of repair, some or all of your stored data may be lost.

We recommend you save this data elsewhere prior to sending the product for repair.



You should also be aware that rather than repairing goods, we may replace them with refurbished goods of the same type or use refurbished parts in the repair process.

Please be assured though, refurbished parts or replacements are only used where they meet ALDI's stringent quality specifications.

If at any time you feel your repair is being handled unsatisfactorily, you may escalate your complaint. Please telephone us on 1300 855 831 or write to us at:

RossMac Pty. Ltd.
P.O. Box 261, Essendon North, Victoria, 3041
1300 855 831
support@schepach.com.au

AFTER SALES SUPPORT

  1300 855 831

 support@schepach.com.au

MODEL: HL650o PRODUCT CODE: 52626 04/2018



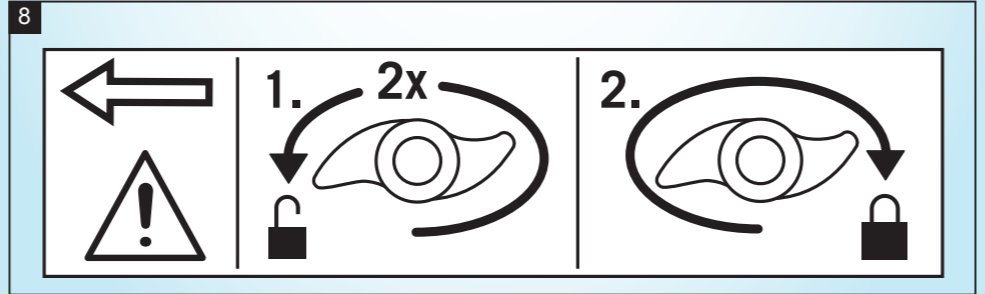
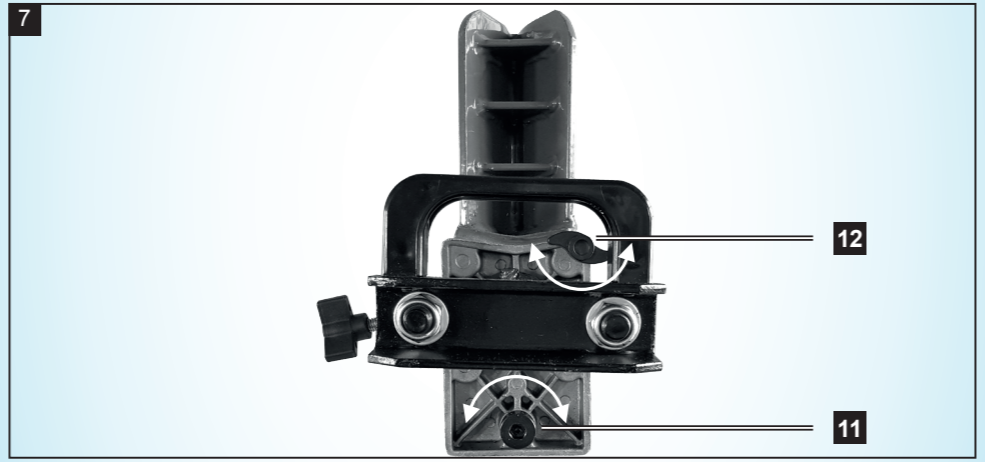
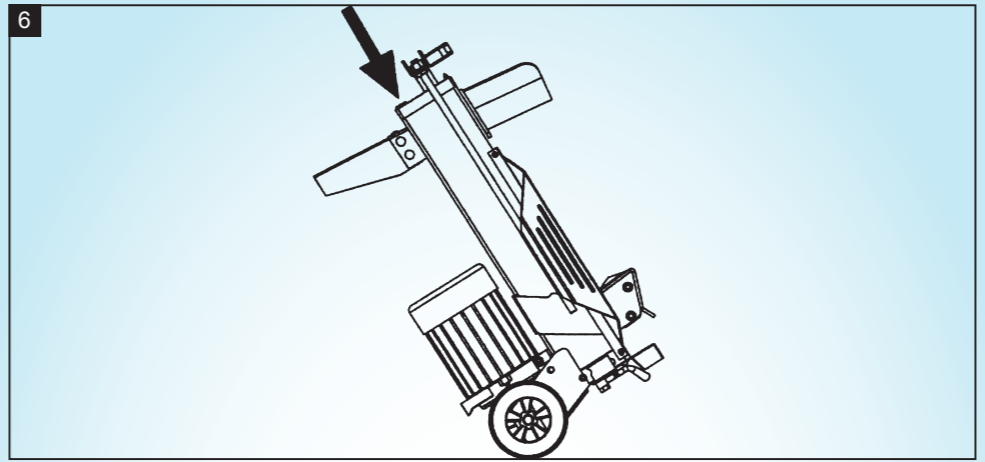
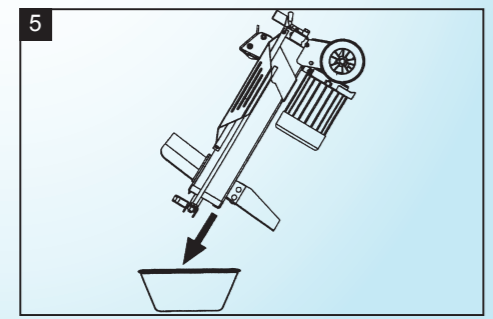
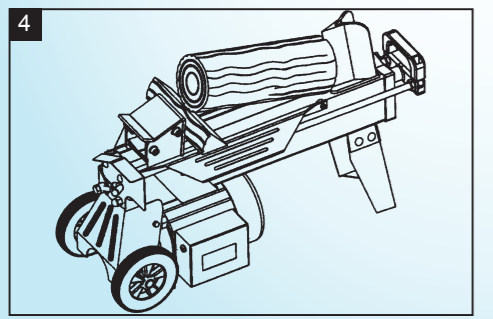
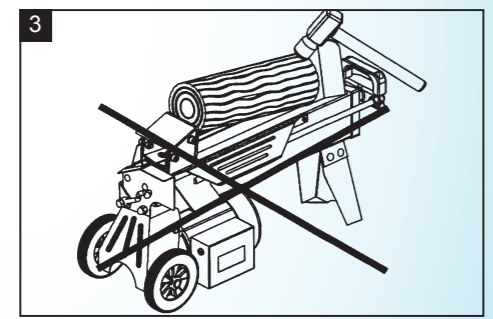
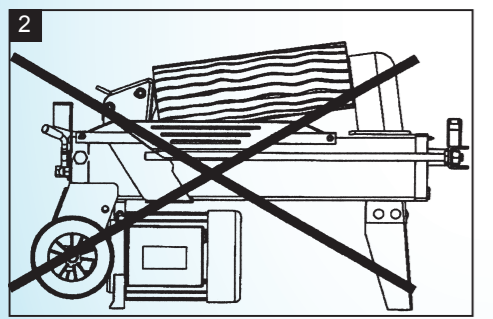
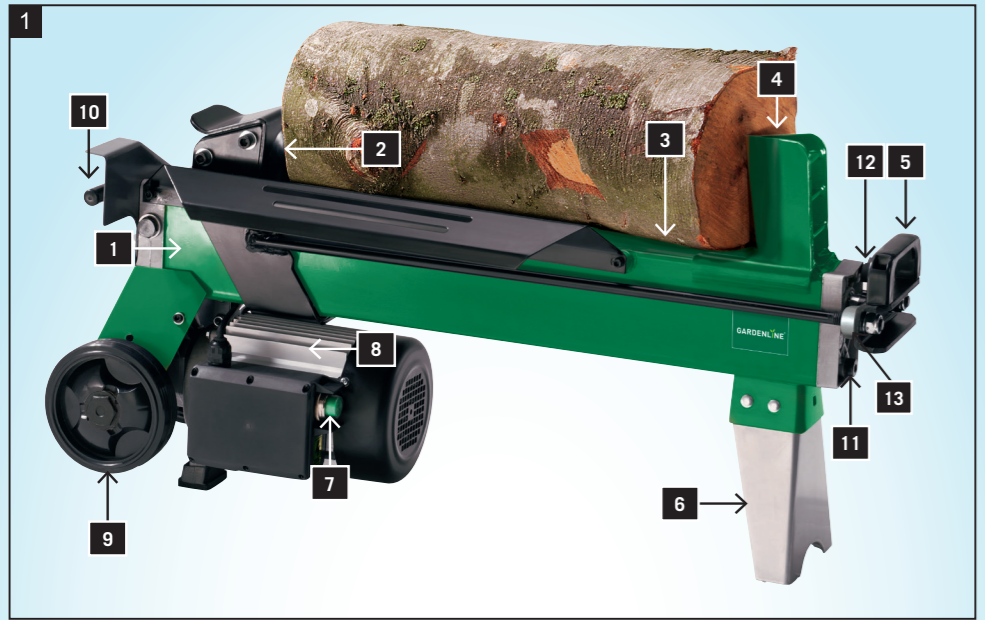

Contents of Box

- 1 Log Splitter
- 2 Instruction Manual
- 3 Warranty Card & Details

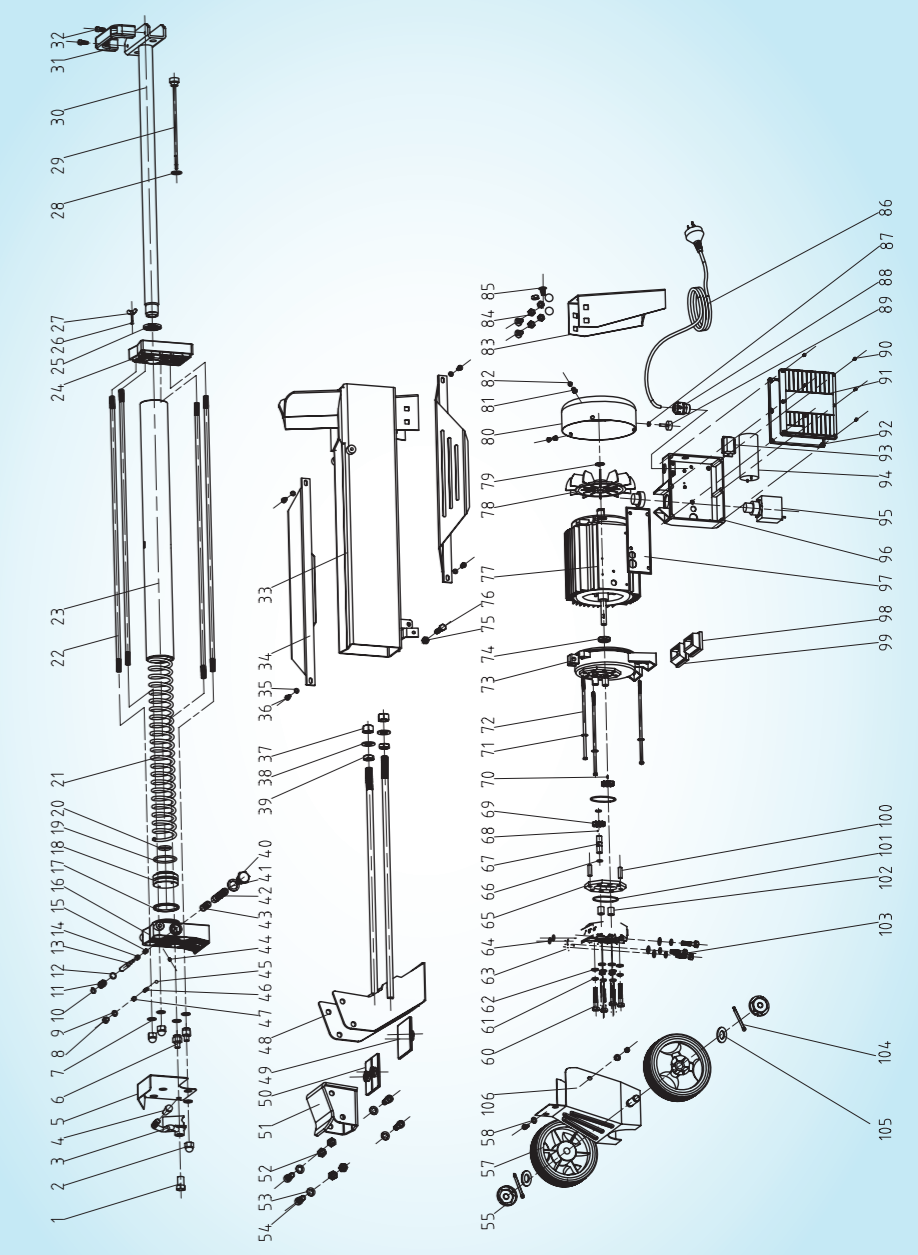

AFTER SALES SUPPORT

support@schepach.com.au

1300 855 831

MODEL: HL650o PRODUCT CODE: 52626 04/2018