



# User Manual

## Contents

- Overview .....04
- Utilisation .....05
- Pack contents / parts .....06
- Explanation of symbols .....07
- Introduction .....08
- Layout .....09
- Unpacking .....09
- Intended use .....09
- Safety regulations .....10
- Assembly .....10
- Operation .....11
- Cleaning .....12
- Maintenance .....12
- Technical data .....12
- Storage and transport .....13
- Disposal and recycling .....13
- Warranty Details .....16
- Repair and Refurbished Goods or Parts Notice .....18

ALDI guarantees that our exclusive brand products are developed to our stringent quality specifications. If you are not entirely satisfied with this product, please return it to the nearest ALDI store within 60 days from the date of purchase, for a full refund or replacement, or take advantage of our after sales support by calling the supplier's Customer Service Hotline.



AUS

## HAND PUSH MOWER 38CM



Vers.No. 180621

Original instruction manual

AUS

### Made in China

GARDENLINE® is a registered trademark of ALDI Stores

DISTRIBUTED BY:

ALDI STORES

1 SARGENTS ROAD

MINCHINBURY NSW 2770

www.aldi.com.au

### AFTER SALES SUPPORT

61621



1300 855 831 (toll free)  
support@scheppach.com.au

MODEL:  
HAND PUSH MOWER 38CM

10/2018

**1**  
YEAR  
WARRANTY

## Explanation of Symbols



Read manual before use.

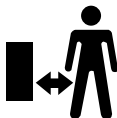

Keep bystanders away.



Risk of injury from parts being thrown up.



Caution! Risk of injury by rotating blade cylinder!  
Keep hands and feet away from the openings when operating the mower.

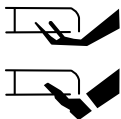

Caution – sharp cutting blade!  
Keep feet and hands away. Risk of injury!

## I. INTRODUCTION

Congratulations on choosing to buy a GARDENLINE® product.

All products brought to you by GARDENLINE® are manufactured to the highest standards of performance and safety, and as part of our philosophy of customer service and satisfaction, are backed by our comprehensive 1 Year Warranty.

We hope you will enjoy using your purchase for many years to come.

### Note:

According to the applicable product liability law the manufacturer of this device is not liable for damages which arise on or in connection with this device in case of:

- improper handling,
- non-compliance with the instructions for use,
- repairs by third party, non-authorized skilled workers,
- installation and replacement of non-original spare parts,
- improper use.

### Recommendations:

Read the entire text of the operating instructions prior to the assembly and operation of the device.

These operating instructions are intended to make it easier for you to get familiar with your device and utilise its intended possibilities of use.

The operating instructions contain important notes on how to work safely, properly and economically with your machine and how to avoid dangers, save repair costs, reduce downtime, and increase the reliability and working life of the machine.

In addition to the safety regulations contained herein, you must in any case comply with the applicable regulations of your country with respect to the operation of the machine.

Put the operating instructions in a clear plastic folder to protect them from dirt and humidity, and store them near the machine. The instructions must be read and carefully observed by each operator prior to starting the work. Only persons who have been trained in the use of the machine and have been informed on the related dangers and risks are allowed to use the machine. The required minimum age must be met.

In addition to the safety notes contained in the present operating instructions and the special regulations of your country, the generally recognised technical rules for the operation of identically constructed machines must be observed.

## II. LAYOUT (Fig. 1/3)

1	Top handle	12	Grass catcher
2	Key	13	Grass catcher frame
3	Key holder	14	Strap
4	Screw	15	Crossbar
5	Centerpiece	16	Wing nut
6	Handle bottom bar	17	Castor
7	Wheel	18	Adjusting screw
8	Handle for height adjustment	19	Cutting blade
9	Mower attachment	20	Sub-blade
10	Star grip screw	21	Blade cylinder
11	Handle holder		

## III. UNPACKING

- Open the packaging and take out the equipment with care.
- Remove the packaging material and any packaging and/or transportation braces (if available).
- Check to see if all items are present.
- Inspect the equipment and accessories for transport damage.  
In case of complaints the supplier is to be informed immediately.
- If possible, keep the packaging until the end of the guarantee period.
- Read the operating instructions to make yourself familiar with the device prior to using it.
- Only use original parts for accessories and spare parts. Spare parts are available from your specialised dealer.
- Specify our part numbers as well as the type and year of construction of the device in your orders.

### **⚠ ATTENTION!**

**The device and packaging materials are not toys!**

**Children must not be allowed to play with plastic bags, film and small parts!**

**There is a risk of swallowing and suffocation!**

## IV. INTENDED USE

The machine is intended only for mowing lawns and grass areas in the domestic domain. This equipment is not suitable for commercial use. Commercial use will invalidate the guarantee. The operator or user is responsible for accidents or injury to other people or damage to their property. The manufacturer shall not be liable for damages caused by improper use or incorrect operation.

## AFTER SALES SUPPORT

  **1300 855 831**

 **support@scheppach.com.au**

MODEL: HAND PUSH MOWER 38CM PRODUCT CODE: 61621

10/2018

## V. SAFETY REGULATIONS

**⚠ Caution:** to avoid accidents and injuries:

- **Children and young people under the age of 16 and people who are not familiar with these instructions must not work with the machine.**
- **Never turn the machine on when people and particularly children or animals are nearby.**
- **People with mental disorders are not allowed to operate the machine without supervision.**
- **Do not use the machine with bare feet or when wearing open sandals. Only run the machine at walking pace.**
- **When working, ensure a firm foothold, particularly on slopes. Always work across the slope, never up or downwards. Take particular care when changing the direction of travel on the slope. Do not work on excessively steep slopes.**
- **When using the machine, avoid feet or hands being trapped between the moving blades and the fixed parts of the machine.**
- **Never carry the machine by the blade cylinder (Fig.3/Pos.21).**

**⚠ Caution:** To avoid damaging the machine and potential injury as a consequence:

- **Check the terrain on which the machine is used and remove stones, sticks, wires or other foreign bodies that may be picked up and flung outwards.**
- **Ensure that the machine is in a safe operating condition. Replace worn or damaged parts.**
- **Protect the machine from the effects of weathering (damp, frost).**

## VI. ASSEMBLY

### **Assembly of the top handle and the handle bottom bars (Fig. 2)**

- Mount the two crossbars (15) with one centerpiece (5), two screws (4) and two wing nuts (16) onto the top handle (1).
- Fix the two handle bottom bars (6) with one centerpiece (5), two screws (4) and two wing nuts (16) at the crossbars (15).

### **Assembly of the handle bottom bars with the mower attachment (Fig. 3)**

- Press the ends of both handle bottom bars (6) together and insert them vertically through the handle holder (11) on the mower attachment (9).
- Push the holes at the end of the handle bottom bars (6) over the two bolts.

### **Assembly of the key holder (Fig. 1)**

- Clip the key holder (3) with the key (2) on the top handle (1).

**Assembly of the grass catcher (Fig. 4)**

- Snap the fastening lugs of the grass catcher (12) over the grass catcher frame (13).

**Attaching the grass catcher (Fig. 1)**

- Attach the assembled grass catcher (12) onto the mower attachment (9) by hooking in at the back side.
- Secure the grass catcher (12) with the strap (14) at the handle of the lawn mower.

**VI. OPERATION****Adjust the cutting height (Fig. 1)**

The cutting height is adjustable from 15 – 44 mm:

- Loosen the star grip screws (10) on both sides of the machine.
- Place one foot on the castor (17) and set the desired cutting height with both hands on the handles for height adjustment (8). Ensure that the machine is set to the same height on both sides.
- Retighten the star grip screws (10).

**Working Instructions**

**⚠ Before each use, check the machine for obvious defects, such as loose, worn or damaged parts. Check that all nuts, bolts and screws are sitting firmly.**

Regular mowing stimulates the stronger formation of leaves in the grass as well as allowing weeds to die off at the same time. Thus, the lawn becomes thicker each time it is mowed and a lawn with even resilience is produced.

- Push the machine at walking pace, in strips that are as straight as possible. For seamless mowing, the strips should always overlap by a few centimetres.
- On slopes, always work across the slope.
- Choose a higher cutting-height for the first cut of season and reduce the height around 20 mm for the subsequent cuts.
- Clean the equipment after each use and store at a dry and frost free place.

**Note!**

Empty the grass catcher (12) after each use.

- Loosen the strap (14) at the handle of the lawn mower.
- Dismount the grass catcher (12) from the mower attachment (9) by hooking out at the backside.
- Re-attach in reverse order.

Let it dry in a well-ventilated area.

**AFTER SALES SUPPORT**

  **1300 855 831**

 **support@scheppach.com.au**

## VII. CLEANING

Neither hose down nor use running water to clean the mower.

- Always keep the machine clean. For cleaning, use a brush or cloth, but no cleaning agents or solvents.
- After mowing, remove any plant remains stuck to the wheels and the blade area.

### **Caution! Risk of injury! Sharp blades - wear gloves**

- Rub the blades with an oil rag or spray them with a metal maintenance spray.
- Due to the special cutting geometry, the blades cannot be re-sharpened. If necessary, the blade cylinder (Fig.3/Pos.21) and sub-blade must therefore be replaced as a set. Have a specialist workshop carry out the installation of the blade cylinder (Fig.3/Pos.21). - **Blades are available from After Sales Support!**

## VIII. MAINTENANCE

### **Adjust the cutting clearance (Fig. 1)**

The sub-blade must be adjusted if the grass is no longer being cut evenly and cleanly.

1. Take the key (2) from the key holder (3).
2. Push a piece of normal paper between the cutting blade (19) and the sub-blade (20).
3. Turn the adjusting screws (18) in a clockwise direction in small steps until the piece of paper sticks slightly.
4. Check the setting by turning the cutting blade. None of the blades should be in contact
5. Put the key (2) in its key holder (3) again.

If it is no longer possible to adjust the cutting clearance, the blades must be replaced as a set. - **Blades are available from After Sales Support!**

## IX. TECHNICAL DATA

Blade width	380 mm
Cutting height	15 - 44 mm
Number of blades	5
Grass catcher capacity approx.	25 L
Weight approx.	8.5 kg

## X. STORAGE AND TRANSPORT

### Storage

Store the equipment and accessories out of children's reach in a dark and dry place at above freezing temperature. The ideal storage temperature is between 5 and 30 °C. Store the machine in its original packaging.

### Transport

- Always carry the mower by its handle and never reach into the cutting mechanism.
- Fit the shipping protectors, if any.
- Protect the machine from damage and the strong vibrations that can occur particularly when transporting in vehicles.
- Secure the machine against slipping and tipping over.

## XI. DISPOSAL AND RECYCLING

The equipment is supplied in packaging to prevent it from being damaged in transit. The raw materials in this packaging can be reused or recycled. The equipment and its accessories are made of various types of material, such as metal and plastic. Never place defective equipment in your household refuse. The equipment should be taken to a suitable collection center for proper disposal. If you do not know the whereabouts of such a collection point, you should ask in your local council offices.

---

## AFTER SALES SUPPORT



AUS 1300 855 831



support@scheppach.com.au





---

## **AFTER SALES SUPPORT**

15

  **1300 855 831**

 **support@scheppach.com.au**

MODEL: HAND PUSH MOWER 38CM PRODUCT CODE: 61621

10/2018



**HAND PUSH MOWER 38CM**

## **Warranty Details**

---

REGISTER YOUR PURCHASE AT [www.aldi.com.au/en/about-aldi/product-registration/](http://www.aldi.com.au/en/about-aldi/product-registration/) TO KEEP UP-TO-DATE WITH IMPORTANT PRODUCT INFORMATION



---

The product is guaranteed to be free from defects in workmanship and parts for a period of 12 months from the date of purchase. Defects that occur within this warranty period, under normal use and care, will be repaired, replaced or refunded at our discretion. The benefits conferred by this warranty are in addition to all rights and remedies in respect of the product that the consumer has under the Competition and Consumer Act 2010 and similar state and territory laws.

Our goods come with guarantees that cannot be excluded under the Australian Consumer Law. You are entitled to a replacement or refund for a major failure and for compensation for any other reasonably foreseeable loss or damage. You are also entitled to have the goods repaired or replaced if the goods fail to be of acceptable quality and the failure does not amount to a major failure.

---

**AFTER SALES SUPPORT**

  **1300 855 831**

 [support@schepach.com.au](mailto:support@schepach.com.au)

MODEL: HAND PUSH MOWER 38CM PRODUCT CODE: 6162110/2018

**1**

YEAR WARRANTY

---

**AFTER SALES SUPPORT**

17

  **1300 855 831**

 **support@scheppach.com.au**

MODEL: HAND PUSH MOWER 38CM PRODUCT CODE: 61621

10/2018



**HAND PUSH MOWER 38CM**

## **Repair and Refurbished Goods or Parts Notice**

Unfortunately, from time to time, faulty products are manufactured which need to be returned to the Supplier for repair.

Please be aware that if your product is capable of retaining user-generated data (such as files stored on a computer hard drive, telephone numbers stored on a mobile telephone, songs stored on a portable media player, games saved on a games console or files stored on a USB memory stick) during the process of repair, some or all of your stored data may be lost.

**We recommend you save this data elsewhere prior to sending the product for repair.**

You should also be aware that rather than repairing goods, we may replace them with refurbished goods of the same type or use refurbished parts in the repair process.

**Please be assured though, refurbished parts or replacements are only used where they meet ALDI's stringent quality specifications.**

If at any time you feel your repair is being handled unsatisfactorily, you may escalate your complaint. Please telephone us on 1300 855 831 or write to us at:

RossMac Pty. Ltd.  
P.O. Box 261, Essendon North, Victoria, 3041  
1300 855 831  
support@scheppach.com.au

**AFTER SALES SUPPORT**  
  **1300 855 831**

 **support@scheppach.com.au**  
MODEL:HAND PUSH MOWER 38CM PRODUCT CODE: 6162110/2018



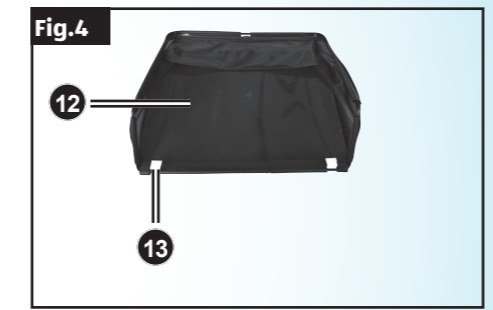
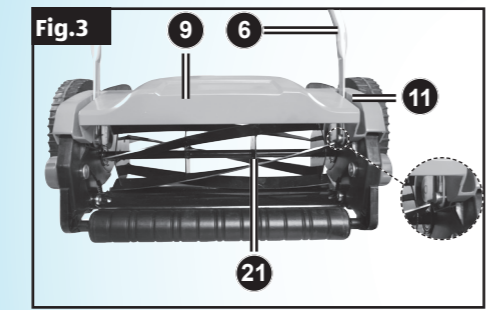
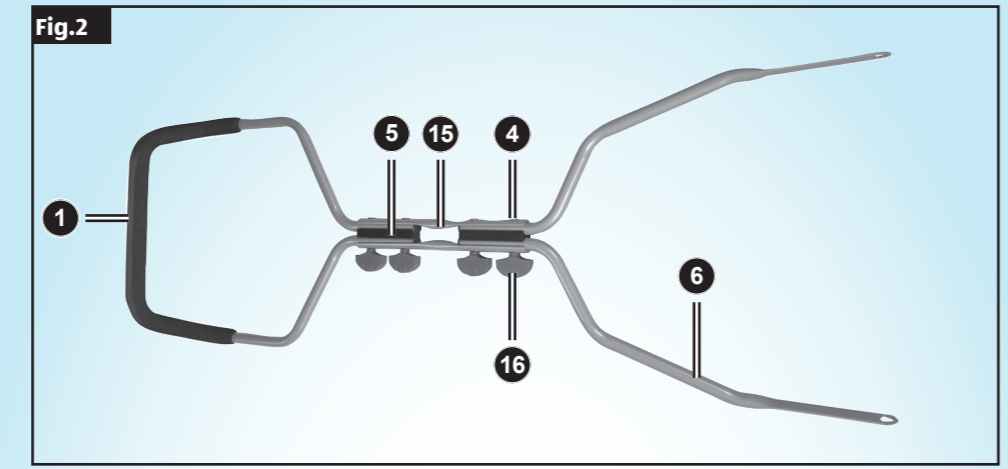
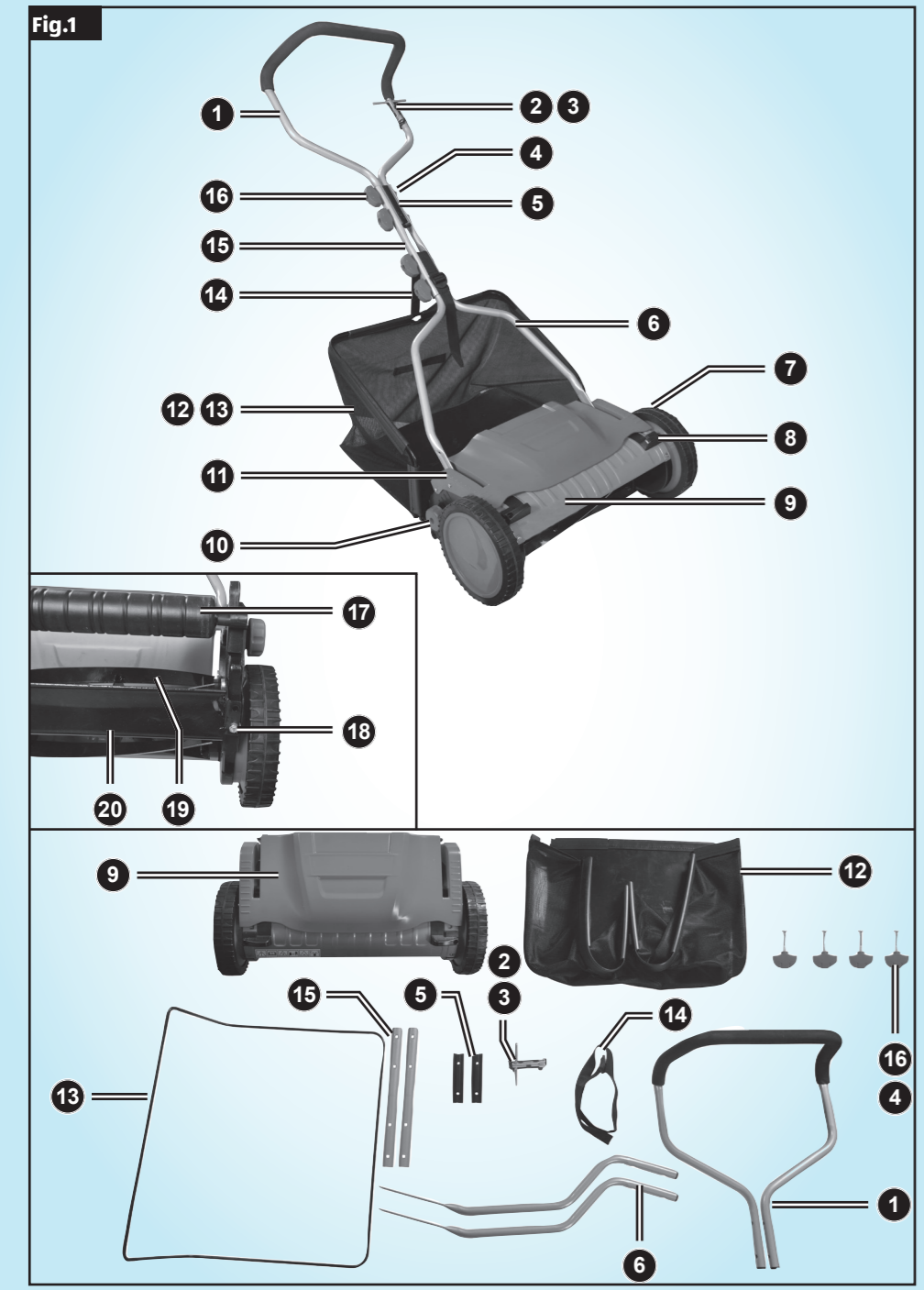

### Pack contents / parts

- 1 1x Top handle
- 2 1x Key
- 3 1x Key holder
- 4 4x Screw
- 5 2x Centerpiece
- 6 1x Mower attachment
- 7 4x Star grip screw
- 8 1x Grass catcher
- 9 1x Grass catcher frame
- 10 1x Strap
- 11 2x Crossbar
- 12 4x Wing nut
- 13 1x Instruction manual
- 14 1x Warranty certificate