



User Manual

Contents

- Overview 03
- Utilisation 04
- Contents of Box 06
- Explanation of symbols 07
- Introduction 08
- Device description 09
- Scope of delivery 09
- Proper use 10
- Safety information 10
- Technical data 16
- Before commissioning 18
- Assembly 18
- Commissioning 19
- Transport 21
- Maintenance and cleaning 21
- Storage 22
- Electrical connection 22
- Disposal and recycling 23
- Troubleshooting 24
- Warranty Details 25
- Repair and refurbished goods or parts notice 26

FERREX® BURNISHING MACHINE



ALDI guarantees that our exclusive brand products are developed to our stringent quality specifications. If you are not entirely satisfied with this product, please return it to the nearest ALDI store within 60 days from the date of purchase, for a full refund or replacement, or take advantage of our after sales support by calling the supplier's Customer Service Hotline.



Made in China

FERREX® is a registered trademark of ALDI Stores

DISTRIBUTED BY:

ALDI STORES
1 SARGENTS ROAD
MINCHINBURY NSW 2770
www.aldi.com.au

AFTER SALES SUPPORT

714785

AUS 1300 855 831

support@scheppach.com.au

MODEL:
F-URM1300-S2

03/2024

5
YEARS
WARRANTY



Original instructions
Warning: Read the instructions before using the machine



Overview

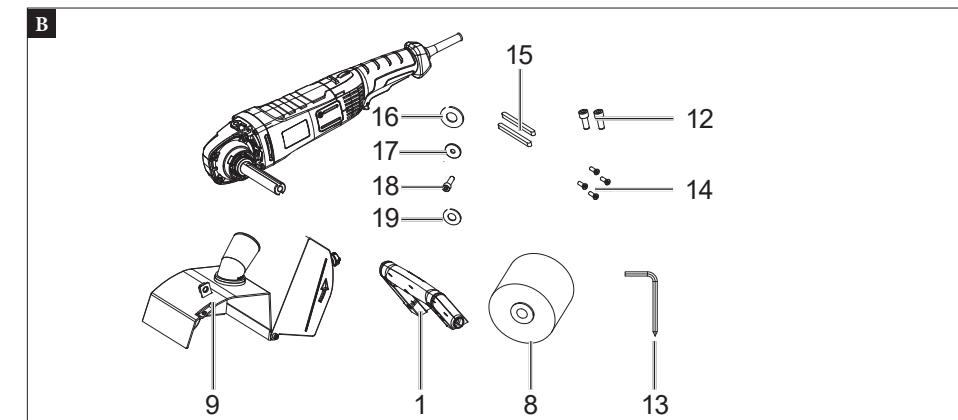
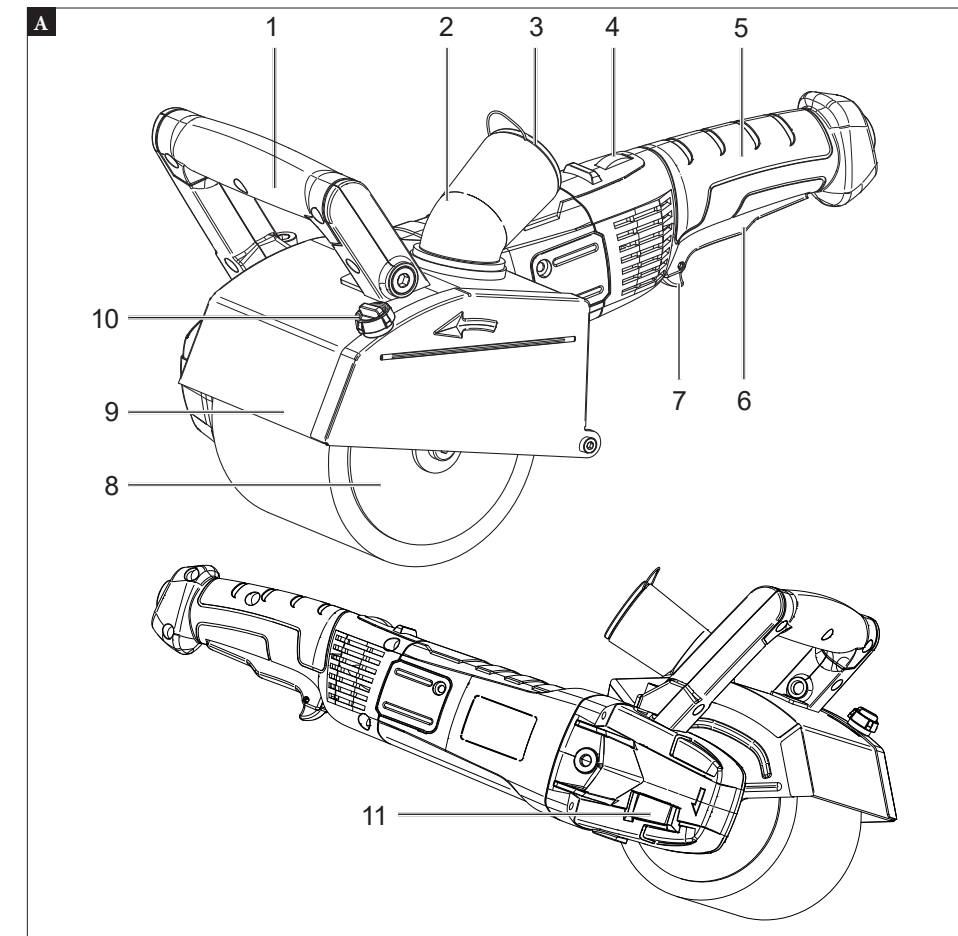

Dok./Rev.-Nr. 714785_2023-09-12

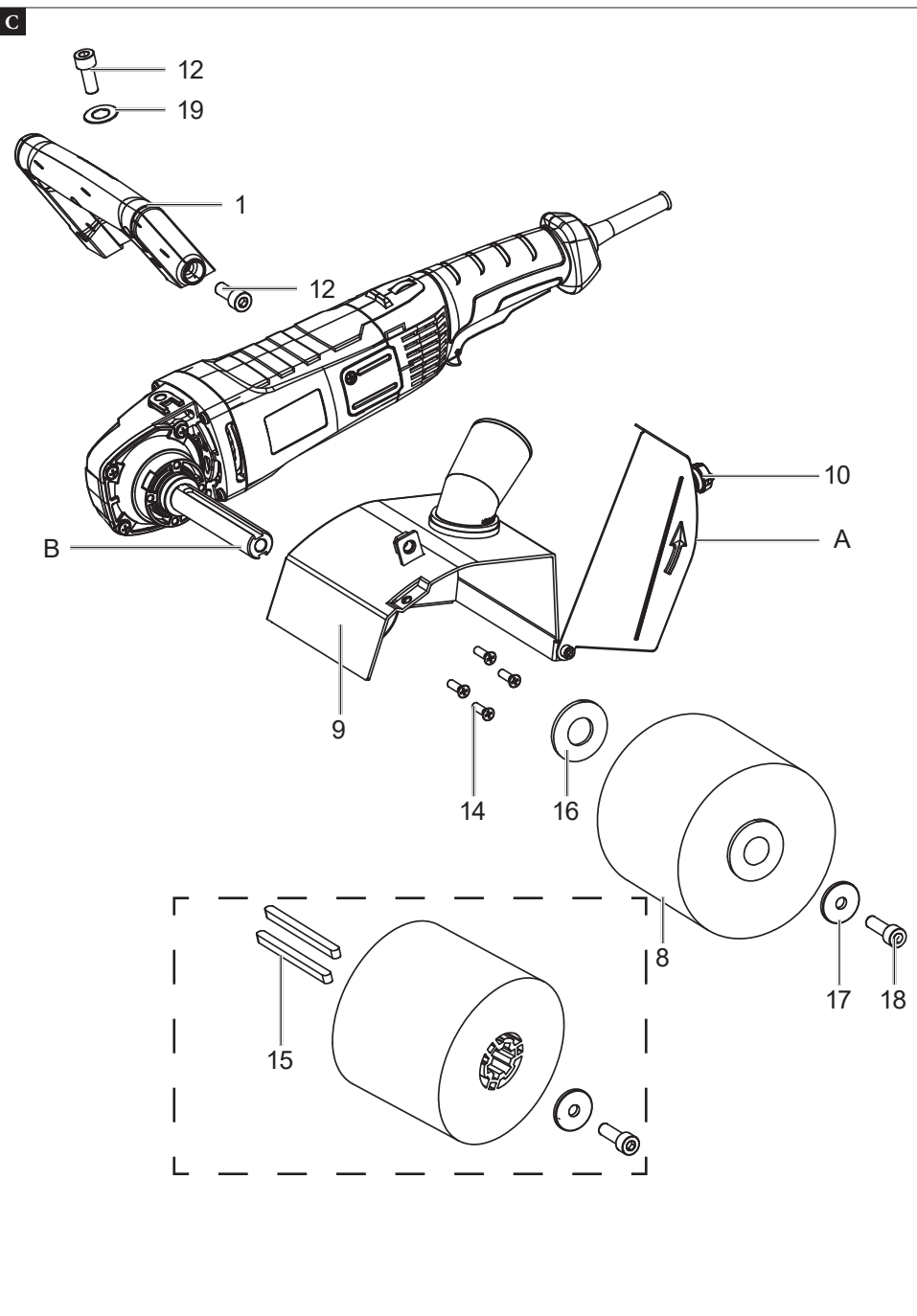





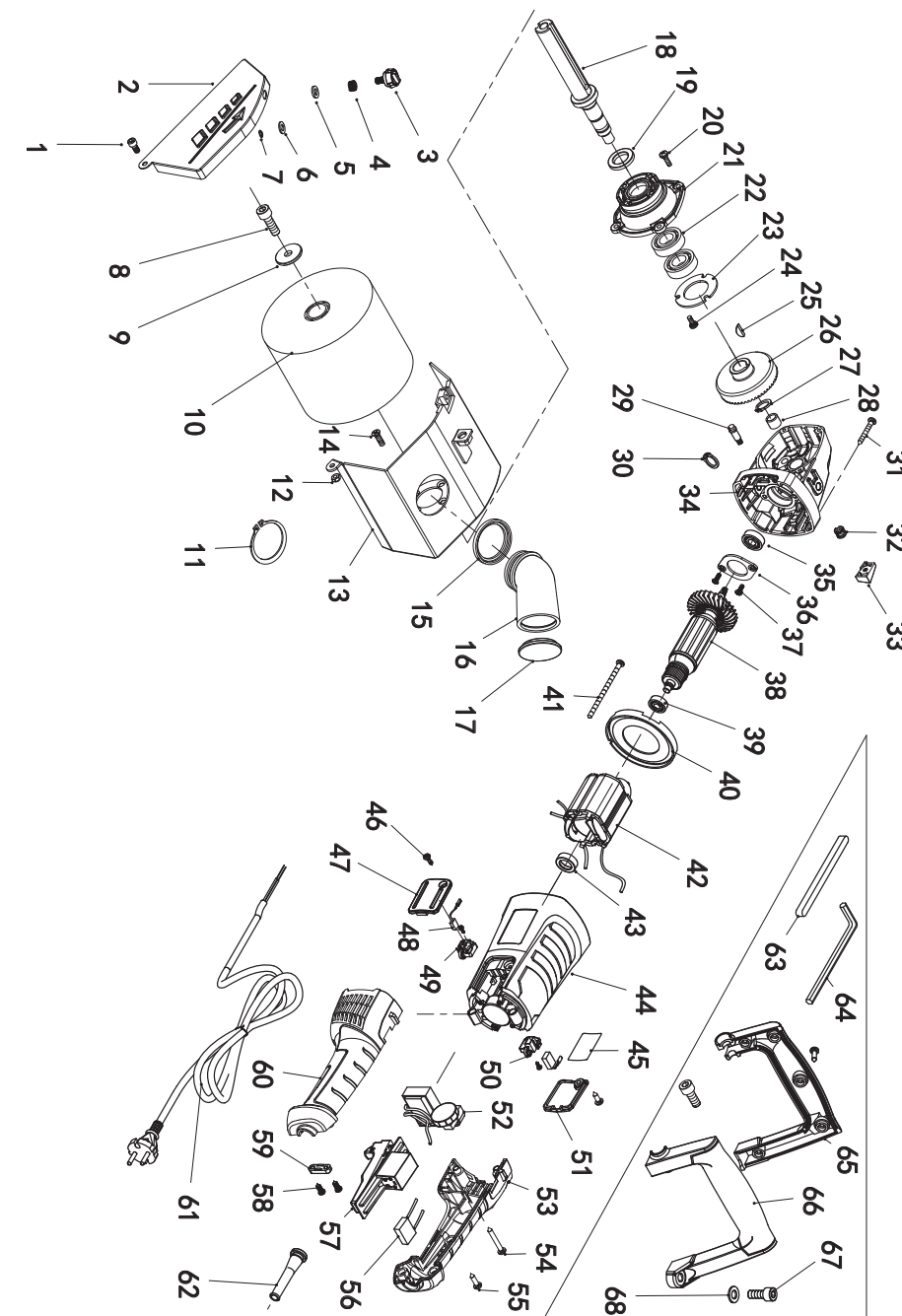



Contents of Box

- 1 x Burnishing machine
- 1 x Front handle
- 1 x Brushing roller brass wire
- 1 x Nylon brush
- 2 x Allen screw
- 1 x Allen key
- 4 x Phillips screw
- 2 x Feather key
- 1 x Big washer
- 1 x Flat washer
- 1 x Clamping screw
- 1 x Small washer
- 1 x Warranty Certificate
- 1 x Manual



Explanation of Symbols

	Read the operating and safety instructions before start-up and follow them!
	Wear hearing protection.
	If dust builds up, wear respiratory protection
	Wear eye protection.
	Wear protective gloves.
	Protection class II (double insulation)
	Warranty period.
	Complies with the Australian EMC requirements and safety standards.
	Warranty class.
⚠ ATTENTION!	We have marked points in these operating instructions that impact your safety with this symbol

I. Introduction

Dear customer,

We hope your new tool brings you much enjoyment and success.

Note:

In accordance with the applicable product liability laws, the manufacturer of this device assumes no liability for damage to the device or caused by the device arising from:

- Improper handling,
- Failure to comply with the operating instructions.
- Repairs carried out by third parties, unauthorised specialists.
- Installing and replacing non-original spare parts.
- Application other than specified.

Please consider:

Read through the complete text in the operating manual before installing and commissioning the device.

The operating manual is intended to help the user to become familiar with the machine and take advantage of its application possibilities in accordance with the recommendations.

The operating manual includes important instructions for safe, proper and economic operation of the device, for avoiding danger, for minimising repair costs and downtimes, and for increasing the reliability and extending the service life of the device.

In addition to the safety instructions in this operating manual, you must also observe the regulations applicable to the operation of the device in your country.

Keep the operating manual package with the machine at all times and store it in a plastic cover to protect it from dirt and moisture. They must be read and carefully observed by all operating personnel before starting the work.

The device may only be used by personnel who have been trained to use it and who have been instructed with respect to the associated hazards. The required minimum age must be observed.

In addition to the safety instructions in this operating manual and the separate regulations of your country, the generally recognised technical rules relating to the operation of such machines must also be observed.

We accept no liability for accidents or damage that occur due to a failure to observe this manual and the safety instructions.

II. Device description (Fig. A, B)

1. Front handle
2. Extraction port
3. Sealing cap
4. Setting wheel for speed preselection
5. Rear handle
6. On/Off switch
7. Switch lock
8. Brushing roller
9. Cover
10. Fixing screw
11. Shaft interlock
12. Allen screw
13. Allen key
14. Phillips screw
15. Feather key
16. Big washer
17. Flat washer
18. Clamping screw
19. Small washer

III. Scope of delivery

- 1x Burnishing machine
- 1x front handle
- 1x brushing roller brass wire
- 1x Nylon brush
- 2x hexagon socket screw
- 1x Allen key
- 4x Phillips screw
- 2x Feather key
- 1x big washer
- 1x Flat washer
- 1x Clamping screw
- 1x small washer
- Warranty certificate
- 1x manual

IV. Proper use

With the appropriate accessories for the respective application, the machine can be used to process metal, plastic and wood surfaces, i.e. grinding, deburring, smoothing, structuring, matting, satin-finishing and polishing. The applications range from coarse sanding to fine sanding and high gloss polishing.

The machine may only be used in the intended manner. Any use beyond this is improper. The user/operator, not the manufacturer, is responsible for damages or injuries of any type resulting from this.

Please observe that our equipment was not designed with the intention of use for commercial or industrial purposes. We assume no guarantee if the equipment is used in commercial or industrial applications, or for equivalent work.

V. Safety information

General power tool safety warnings

⚠ WARNING: Read all safety warnings, instructions, illustrations and specifications provided with this electric tool. Failure to follow all instructions listed below may result in electric shock, fire and/or serious injury.

Save all warnings and instructions for future reference.

The term “power tool” in the warnings refers to your mains-operated (corded) power tool or battery-operated (cordless) power tool.

1. Work area safety

- a) **Keep work area clean and well lit.** Cluttered or dark areas invite accidents.
- b) **Do not operate power tools in explosive atmospheres, such as in the presence of flammable liquids, gases or dust.** Power tools create sparks which may ignite the dust or fumes.
- c) **Keep children and bystanders away while operating a power tool.** Distractions can cause you to lose control.

2. Electrical safety

- a) **Power tool plugs must match the outlet. Never modify the plug in any way. Do not use any adapter plugs with earthed (grounded) power tools.** Unmodified plugs and matching outlets will reduce risk of electric shock.

- b) **Avoid body contact with earthed or grounded surfaces, such as pipes, radiators, ranges and refrigerators.** There is an increased risk of electric shock if your body is earthed or grounded.
- c) **Do not expose power tools to rain or wet conditions.** Water entering a power tool will increase the risk of electric shock.
- d) **Do not abuse the cord. Never use the cord for carrying, pulling or unplugging the power tool. Keep cord away from heat, oil, sharp edges or moving parts.** Damaged or entangled cords increase the risk of electric shock.
- e) **When operating a power tool outdoors, use an extension cord suitable for outdoor use.** Use of a cord suitable for outdoor use reduces the risk of electric shock.
- f) **If operating a power tool in a damp location is unavoidable, use a residual current device (RCD) protected supply.** Use of an RCD reduces the risk of electric shock.

3. Personal safety

- a) **Stay alert, watch what you are doing and use common sense when operating a power tool. Do not use a power tool while you are tired or under the influence of drugs, alcohol or medication.** A moment of inattention while operating power tools may result in serious personal injury.
- b) **Use personal protective equipment. Always wear eye protection.** Protective equipment such as a dust mask, non-skid safety shoes, hard hat or hearing protection used for appropriate conditions will reduce personal injuries.
- c) **Prevent unintentional starting. Ensure the switch is in the off-position before connecting to power source and/or battery pack, picking up or carrying the tool.** Carrying power tools with your finger on the switch or energising power tools that have the switch on invites accidents.
- d) **Remove any adjusting key or wrench before turning the power tool on.** A wrench or a key left attached to a rotating part of the power tool may result in personal injury.
- e) **Do not overreach. Keep proper footing and balance at all times.** This enables better control of the power tool in unexpected situations.
- f) **Dress properly. Do not wear loose clothing or jewellery. Keep your hair and clothing away from moving parts.** Loose clothes, jewellery or long hair can be caught in moving parts.
- g) **If devices are provided for the connection of dust extraction and collection facilities, ensure these are connected and properly used.** Use of dust collection can reduce dust-related hazards.

- h) Do not let familiarity gained from frequent use of tools allow you to become complacent and ignore tool safety principles.** A careless action can cause severe injury within a fraction of a second.

4. Power tool use and care

- a) Do not force the power tool. Use the correct power tool for your application.** The correct power tool will do the job better and safer at the rate for which it was designed.
- b) Do not use the power tool if the switch does not turn it on and off.** Any power tool that cannot be controlled with the switch is dangerous and must be repaired.
- c) Disconnect the plug from the power source and/or remove the battery pack, if detachable, from the power tool before making any adjustments, changing accessories, or storing power tools.** Such preventive safety measures reduce the risk of starting the power tool accidentally.
- d) Store idle power tools out of the reach of children and do not allow persons unfamiliar with the power tool or these instructions to operate the power tool.** Power tools are dangerous in the hands of untrained users.
- e) Maintain power tools and accessories. Check for misalignment or binding of moving parts, breakage of parts and any other condition that may affect the power tool's operation.** If damaged, have the power tool repaired before use. Many accidents are caused by poorly maintained power tools.
- f) Keep cutting tools sharp and clean.** Properly maintained cutting tools with sharp cutting edges are less likely to bind and are easier to control.
- g) Use the power tool, accessories and tool bits etc. in accordance with these instructions, taking into account the working conditions and the work to be performed.** Use of the power tool for operations different from those intended could result in a hazardous situation.
- h) Keep handles and grasping surfaces dry, clean and free from oil and grease.** Slippery handles and grasping surfaces do not allow for safe handling and control of the tool in unexpected situations.

5. Service

- a.) Have your power tool serviced by a qualified repair person using only identical replacement parts.** This will ensure that the safety of the power tool is maintained.

Safety instructions for all applications

Common safety instructions for grinding, working with wire brushes, polishing:

- a) **This electric tool is to be used as a grinder, wire brush, polishing. Read all safety warnings, instructions, illustrations and data that are received with the device.** Failure to observe all the following instructions may result in electric shock, fire and / or serious injury.
- b) **This electric tool is not suitable for hole cutting and cut-off grinding.** Operations for which the power tool was not designed may create a hazard and cause personal injury.
- c) **Do not use a tool attachment that has not been specifically envisaged and recommended by the manufacturer for this electric tool.** Just because the accessory can be attached to your power tool, it does not assure safe operation.
- d) **The rated speed of the accessory must be at least equal to the maximum speed marked on the power tool.** Tool attachment that rotate faster than permitted can break and fly off at high speed.
- e) **The outside diameter and the thickness of your accessory must be within the capacity rating of your power tool.** Incorrectly sized accessories cannot be adequately guarded or controlled.
- f) **Insert tools with threaded inserts must fit exactly on the thread of the grinding spindle. For insert tools that are mounted by means of a flange, the hole diameter of the insert tool must match the mounting diameter of the flange.** Insert tools which are not precisely attached to the electric tool rotate unevenly, vibrate very strongly and can cause a loss of control.
- g) **Do not use a damaged accessory. Before each use inspect the accessory such as abrasive wheels for chips and cracks, backing pad for cracks, tear or excess wear, wire brush for loose or cracked wires. If power tool or accessory is dropped, inspect for damage or install an undamaged accessory. After inspecting and installing an accessory, position yourself and bystanders away from the plane of the rotating accessory and run the power tool at maximum no-load speed for one minute.** Damaged tool attachments normally break during this test period.
- h) **Wear personal protective equipment. Depending on application, use face shield, safety goggles or safety glasses. Where appropriate, wear a dust mask, hearing protection, protective gloves or a special apron that will keep small grinding and material particles away from you.** The eye protection must be capable of stopping flying debris generated by various operations. Dust or breathing masks must filter the dust generated during use. Prolonged exposure to

high intensity noise may cause hearing loss.

- i) **Keep bystanders a safe distance away from work area. Anyone entering the work area must wear personal protective equipment.** Fragments of workpiece or of a broken accessory may fly away and cause injury beyond immediate area of operation.
- j) **When performing work during which the insert tool can meet with concealed power lines or its own mains cable, only hold the electric tool by the insulated gripping surfaces.** Contact with a live power line can also electrify metal device parts and lead to an electric shock.
- k) **Position the cord clear of the spinning accessory.** If you lose control, the cord may be cut or snagged and your hand or arm may be pulled into the spinning accessory.
- l) **Never lay the power tool down until the accessory has come to a complete stop.** The spinning accessory may grab the surface and pull the power tool out of your control.
- m) **Do not run the power tool while carrying it at your side.** Accidental contact with the spinning accessory could snag your clothing, pulling the accessory into your body.
- n) **Regularly clean the power tool's air vents.** The motor's fan will draw the dust inside the housing and excessive accumulation of powdered metal may cause electrical hazards.
- o) **Do not operate the power tool near flammable materials.** Sparks could ignite these materials.
- p) **Do not use accessories that require liquid coolants.** Using water or other liquid coolants may result in electrocution or shock.

Further safety instructions for all applications

Kick-back and corresponding safety instructions

Kick-back is the sudden reaction resulting from a caught or jammed rotating insert tool, such as a grinding disc, grinding wheel, wire brush, etc. catching or jamming results in the rotating insert tool stopping abruptly. As a result, an uncontrolled electric tool is accelerated against the direction of rotation of the tool attachment at the blocking point.

For example, if an abrasive wheel is snagged or pinched by the workpiece, the edge of the wheel that is entering into the pinch point can dig into the surface of the material causing the wheel to climb out or kick out. The wheel may either jump toward or away from the operator, depending on direction of the wheel's movement at the point of

pinching. Abrasive wheels may also break under these conditions.

Kick-back is the result of incorrect use of the electric tool and/or deficient working conditions. It can be prevented by suitable precautionary measures, as described in the following.

- a) **Maintain a firm grip on the power tool and position your body and arm to allow you to resist kickback forces. Always use auxiliary handle, if provided, for maximum control over kickback or torque reaction during start-up.** The operator can control torque reactions or kickback forces, if proper precautions are taken.
- b) **Never place your hand near the rotating accessory.** Accessory may kickback over your hand.
- c) **Avoid the area with your body where the electric tool will be moved in the event of a kick-back.** Kickback will propel the tool in direction opposite to the wheel's movement at the point of snagging.
- d) **Be particularly careful when working in the area of the corners, sharp edges etc. Prevent insert tools from bouncing against the workpiece and getting caught.** The rotating tool attachment tends to jam at corners, sharp edges or when it gets caught. This causes a loss of control or kick-back.
- e) **Do not use the chainsaw blade to cut wood, a segmented diamond cutting wheel with a segment gap over 10 mm or a toothed saw blade.** Such insert tools frequently cause kick-back and loss of control.

Special safety instructions for polishing:

- a) **Do not allow any loose parts of the polishing cover, especially fastening string. Stow or shorten the fastening string.** Loose, rotating fastening cords can catch your fingers or get caught in the workpiece.

Special safety instructions for working with wire brushes:

- a) **Note that the wire brush loses pieces of wire even during normal use. Do not overtax the wires by applying too much contact pressure.** Pieces of wire that fly off can easily penetrate thin clothing and/or the skin.
- b) **If a protective cover is recommended, prevent the protective cover and wire brushes from touching.** Disc and cup brushes can increase their diameter due to contact pressure and centrifugal forces.

Residual risks

The electric tool has been built according to state-of-the-art and the recognised technical safety rules. However, individual residual risks can arise during operation.

- Health hazard due to electrical power, with the use of improper electrical connection cables.
- Furthermore, despite all precautions having been met, some non-obvious residual risks may still remain.
- Residual risks can be minimised if the “Important information” and the “Proper use” are observed along with the whole of the operating instructions.
- Avoid accidental starting of the machine: the start button may not be pressed when inserting the plug in an outlet.
- Keep your hands away from the work area, when the machine is in operation.
- Before performing setting or maintenance work, release the start button and pull out the power plug.

⚠ WARNING

This electric tool generates an electromagnetic field during operation. This field can impair active or passive medical implants under certain conditions. In order to prevent the risk of serious or deadly injuries, we recommend that persons with medical implants consult with their physician and the manufacturer of the medical implant prior to operating the electric tool.

VI. Technical data

Rated voltage	220 - 240 V~ / 50/60 Hz
Rated input	1300 W
Protection class	II
Idle speed n_0	900-3200 min ⁻¹
Tool attachment \emptyset	\emptyset 120 x 100 mm
Suction connection	\emptyset 35 mm
Weight	4.6 kg
Dimensions L x W x H	460 x 205 x 140 mm

Noise/vibration information

⚠ WARNING!

Working without hearing protection or protective clothing can result in damage to health.

- Wear hearing protection and appropriate protective clothing when working.

Measured as per AS/NZS 62841.1 and AS/NZS 62841.2.4. The noise at the work place can exceed 85 dB. In this case, protective measures for the user are required (wear suitable hearing protection).

Sound power level L_{WA}	109 dB
Sound pressure level L_{pA}	98 dB
Uncertainty $K_{wa/pA}$	3 dB

The above mentioned values are device emissions values and therefore do not necessarily represent safe work place values. The correlation between emission and exposure levels cannot reliably lead to a derivation of whether additional precautionary measures are necessary or not.

Factors that could influence the respective emissions level present at the work place include the specification of the working area and the environment, the duration of exposure, other noise sources and more.

Also pay attention to any possible deviations in the national regulations for the reliable work place values. However, the above mentioned information makes it possible for the user to make a better assessment of the dangers and risks.

Vibration emissions value a^h (vector sum, three directions) and uncertainty K determined per AS/NZS 62841.1 and AS/NZS 62841.2.4:

Vibration emission value (3-axle)

Typical weighed vibration a_n = 7,85 m/s²,
 Uncertainty K = 1.5 m/s²

VII. Before commissioning

- Open the packaging and carefully remove the device.
- Remove the packaging material, as well as the packaging and transport safety devices (if present).
- Check whether the scope of delivery is complete.
- Check the device and accessory parts for transport damage.
- If possible, keep the packaging until the expiry of the warranty period.

⚠ ATTENTION

The device and the packaging are not children's toys! Do not let children play with plastic bags, films or small parts! There is a danger of choking or suffocating!

- The brushing roller must be able to run freely.
- Before pressing the on/off switch, make sure that the brushing roller is correctly fitted and that moving parts run smoothly.
- Before connecting the machine, make certain that the data on the type plate matches with the mains power data.

Connection to the mains

Check whether the network to which you connect the machine is properly earthed according to the valid standards and whether the outlet is in good condition.

VIII. Assembly

⚠ WARNING! Electric shock

Unplug the mains plug from the socket before carrying out any work on the machine!

Installing the cover and front handle (Fig. C)

1. Align the holes in the cover (9) with the holes on the device and bolt them together with the Phillips-head screws (14). Use the Allen key (13) for this.
2. Put the front handle (1) onto the screw-on points on the unit and secure it with the small washer (19) and the Allen screws (12). Use the Allen key (13) for this purpose.

Fitting/replacing the brushing roller (Fig. A + C)

1. Loosen the fixing screw (10) and fold the cover (A) to the side.
2. Push the brushing roller (8) onto the motor shaft (B). Depending on whether the

- brushing roller (8) has feather key grooves, make sure that the feather keys (15) are in the grooves of the motor shaft (B) and the big washer (16) is mounted.
- Secure the brushing roller (8) by actuating the shaft interlock (11) and tightening the clamping screw (18) with the spring washer (17).
 - Close the cover (A) and secure it with the fixing screw (10).
 - Disassembly takes place in reverse order.

IX. Commissioning

⚠ Attention!

Always make sure the device is fully assembled before commissioning!

Brass wire brush (Art. No. 7903800718)

Machining type: Grinding, deburring, stripping

Suitable for: Wood, stone, metal

Nylon brush (Art. No. 7903800715)

Machining type: Clean

Suitable for: Flat and irregular wood, stone, metal surfaces, as well as for degreasing and scrubbing

Only use manufacturer's recommended original brushing rollers.

Brushing rollers can be obtained from your dealer.

Replace or mount the brushing roller as described in the Maintenance and cleaning chapter.

Switching on/off (fig. A)

⚠ ATTENTION! Always guide the device with both hands.

⚠ ATTENTION! First, switch the device on and wait until the brushing roller (8) has reach maximum speed before starting work on the workpiece.

- Always hold the device with one hand on the front handle (1) and the other on the rear handle (5).
- Switching on: Push the switch lock (7) forwards and press the on/off switch (6).
- Switching off: Release the on/off switch (6) and wait until the brushing roller (8) comes to a full stand still before putting the device down.

Setting the speed (fig. A)

1. Use a speed adapted to the application in order to prevent damage to the material.
2. Select the desired speed for the speed preselection (4) using the setting wheel.
3. The required speed is dependent on the material and the working conditions and can be determined with a practical trial.

Connection to an external dust extraction system (fig. A)

⚠ ATTENTION! An external dust extraction system must not be connected when carrying out work that generates sparks.

The dust extraction system must be suitable for the material to be processed.

Use a special extraction device to extract dusts that are particularly harmful to health or carcinogenic.

1. Remove the sealing cap (3) from the suction port (2).
2. Connect a suitable dust extraction to the suction port (2).

General working notes

- The work result and the surface quality are essentially determined by the choice of brushing roller and by the preselected speed.
- Work with the contact pressure as low as possible in order to increase the service life of the brushing roller. Excessively increasing the contact pressure does not lead to a higher removal/cleaning rate, but to greater wear of the device and the brushing roller.
- Work with moderate feed and carry out the working process parallel and overlapping to the grinding path.
- Use only original accessories from the manufacturer.
- Only perfect brushing rollers provide good work results and protect the device.
- Make sure that the workpiece is always clamped and secured in order to prevent ejection.

XI. Transport

Always switch off the power tool before transport and disconnect it from the power supply.

To transport the power tool, lift it by the centre struts.

Protect the electrical tool from impacts, shocks and severe vibrations, e.g. during vehicular transport.

Secure the power tool against toppling and slipping.

XII. Maintenance and cleaning

⚠ WARNING!

Pull out the mains plug before carrying out any adjustments, maintenance or repair work!

General maintenance tasks

- Always keep the cooling air openings in the housing clean and clear for air circulation.
- Rub the device clean with a clean cloth or blow it off with compressed air at low pressure.
- We recommend that you clean the device directly after every use.
- Clean the device at regular intervals using a damp cloth and a little soft soap. Do not use any cleaning products or solvents; they could attack the plastic parts of the device. Make sure that no water can penetrate the device interior.
- There are no parts which can be repaired by the user within the device. Never try to repair the device yourself. Always contact the manufacturer or his agent.

Replacing the connection cable

If the mains connection cable of the burnishing machine is damaged, it must be replaced by the manufacturer, their service department or a similarly qualified person to avoid dangers.

Service information

With this product, it is necessary to note that the following parts are subject to natural or usage-related wear, or that the following parts are required as consumables.

Wearing parts*: Carbon brushes, brushing roller

* may not be included in the scope of supply!

Spare parts and accessories can be obtained from our service centre.

XIII. Storage

Store the device and its accessories in a dark, dry and frost-free place that is inaccessible to children. The optimum storage temperature lies between 5 and 30 °C.

Store the power tool in its original packaging.

Cover the electric tool to protect it from dust or moisture.

Store the operating manual with the power tool.

XIV. Electrical connection

The electrical motor installed is connected and ready for operation. The connection with the applicable local electrical regulations. The customer's mains connection as well as the extension cable used must also comply with these regulations.

Important information

In the event of overloading, the motor will switch itself off. After a cool-down period (time varies) the motor can be switched back on again.

Damaged electrical connection cable

The insulation on electrical connection cables is often damaged.

This may have the following causes:

- Pressure points, where connection cables are passed through windows or doors.
- Kinks where the connection cable has been improperly fastened or routed.
- Places where the connection cables have been cut due to being driven over.
- Insulation damage due to being ripped out of the wall outlet.
- Cracks due to the insulation ageing.

Such damaged electrical connection cables must not be used and are life-threatening due to the insulation damage.

Check the electrical connection cables for damage regularly. Ensure that the connection cables are disconnected from electrical power when checking for damage.

Electrical connection cables must comply with the applicable local electrical regulations. Only use connection cables with designation H05VV-F.

The printing of the type designation on the connection cable is mandatory.

AC motor

- The mains voltage must be 220-240 V~
- Extension cables up to 25 m long must have a cross-section of 1.5 square millimetres.

Connections and repair work on the electrical equipment may only be carried out by electricians.

Connection type Y

If the mains connection cable of this device is damaged, it must be replaced by the manufacturer or his agent to avoid dangers.

Please provide the following information in the event of any enquiries:

- Type of current for the motor
- Data of machine type plate

XV. Disposal and recycling

- The equipment is supplied in packaging to prevent it from being damaged in transit. The raw materials in this packaging can be reused or recycled. The equipment and its accessories are made of various types of material, such as metal and plastic. Never place defective equipment in your household refuse. The equipment should be taken to a suitable collection center for proper disposal.
- If you do not know the whereabouts of such a collection point, you should ask in your local council offices.

XVI. Troubleshooting

Fault	Possible cause	Remedy
Motor does not work	Motor, cable or plug defective, fuses burnt	Arrange for inspection of the machine by a specialist. Never repair the motor yourself. Danger! Check fuses and replace if necessary
The engine runs slowly and does not reach the operating speed.	Voltage too low, coils damaged, capacitor burnt	Contact the utility provider to check the voltage. Arrange for inspection of the motor by a specialist. Arrange for replacement of the capacitor by a specialist
Motor makes excessive noise	Coils damaged, motor defective	Arrange for inspection of the motor by a specialist
The motor does not reach its full power.	Circuits in the network are overloaded (lamps, other motors, etc.)	Do not use any other equipment or motors on the same circuit
Motor overheats easily.	Overloading of the motor, insufficient cooling of the motor	Avoid overloading the motor, remove dust from the motor in order to ensure optimal cooling of the motor



ALDI

FERREX[®]

BURNISHING MACHINE



Warranty Details

REGISTER YOUR PURCHASE AT www.aldi.com.au/en/about-aldi/product-registration/ TO KEEP UP-TO-DATE WITH IMPORTANT PRODUCT INFORMATION

The product is guaranteed to be free from defects in workmanship and parts for a period of 60 months from the date of purchase. Defects that occur within this warranty period, under normal use and care, will be repaired, replaced or refunded at our discretion. The benefits conferred by this warranty are in addition to all rights and remedies in respect of the product that the consumer has under the Competition and Consumer Act 2010 and similar state and territory laws.

Our goods come with guarantees that cannot be excluded under the Australian Consumer Law. You are entitled to a replacement or refund for a major failure and for compensation for any other reasonably foreseeable loss or damage. You are also entitled to have the goods repaired or replaced if the goods fail to be of acceptable quality and the failure does not amount to a major failure.

AFTER SALES SUPPORT

  **1300 855 831**

 **support@scheppach.com.au**

MODEL: F-URM1300-S2 PRODUCT CODE: 714785 03/2024

5

YEAR WARRANTY



ALDI
FERREX[®]
BURNISHING MACHINE

Repair and Refurbished Goods or Parts Notice

Unfortunately, from time to time, faulty products are manufactured which need to be returned to the Supplier for repair.

Please be aware that if your product is capable of retaining user-generated data (such as files stored on a computer hard drive, telephone numbers stored on a mobile telephone, songs stored on a portable media player, games saved on a games console or files stored on a USB memory stick) during the process of repair, some or all of your stored data may be lost.

We recommend you save this data elsewhere prior to sending the product for repair.

You should also be aware that rather than repairing goods, we may replace them with refurbished goods of the same type or use refurbished parts in the repair process.

Please be assured though, refurbished parts or replacements are only used where they meet ALDI's stringent quality specifications.



If at any time you feel your repair is being handled unsatisfactorily, you may escalate your complaint. Please telephone us on 1300 855 831 or write to us at:

RossMac Pty. Ltd.

Unit 6, 4 Ovata Drive, Tullamarine, Victoria, 3043

support@scheppach.com.au

AFTER SALES SUPPORT

  1300 855 831

 support@scheppach.com.au

MODEL:F-URM1300-S2 PRODUCT CODE: 714785 03/2024

5

YEAR WARRANTY