



User Manual

Contents

- Explanation of Symbols 10
- Introduction 11
- Device description.....12
- Unpacking 13
- Intended use 13
- Safety regulations.....14
- Technical data24
- Before starting the equipment25
- Assembly25
- Setup.....28
- Operation.....29
- Transport33
- Maintenance34
- Storage34
- Electrical connection.....34
- Disposal and recycling35
- Troubleshooting.....36
- Warranty Details.....37
- Repair and Refurbished Goods or Parts Notice38

FERREX®

TABLE SAW



Original instructions
Vers.No. 200408

ALDI guarantees that our exclusive brand products are developed to our stringent quality specifications. If you are not entirely satisfied with this product, please return it to the nearest ALDI store within 60 days from the date of purchase, for a full refund or replacement, or take advantage of our after sales support by calling the supplier's Customer Service Hotline.



Made in China

FERREX® is a registered trademark of ALDI Stores

DISTRIBUTED BY:

ALDI STORES
1 SARGENTS ROAD
MINCHINBURY NSW 2770
www.aldi.com.au

AFTER SALES SUPPORT

702192

1300 855 831

support@schepach.com.au

MODEL:
DX254TS

09/2020

3
YEARS
WARRANTY

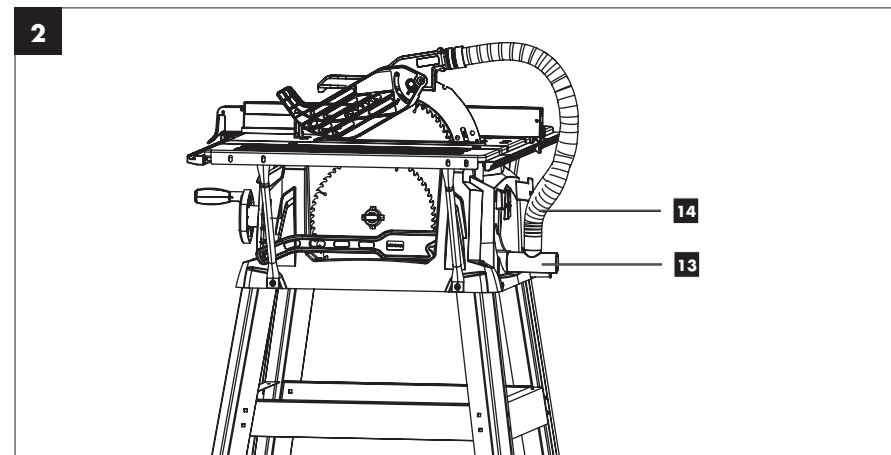
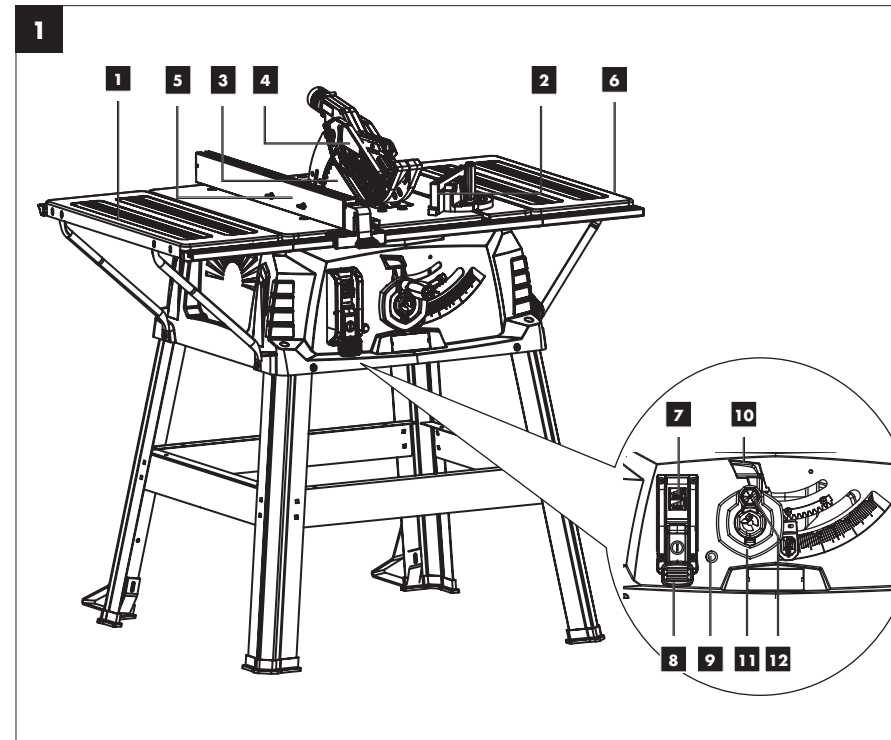

Dok./Rev.-Nr. 702192_200408

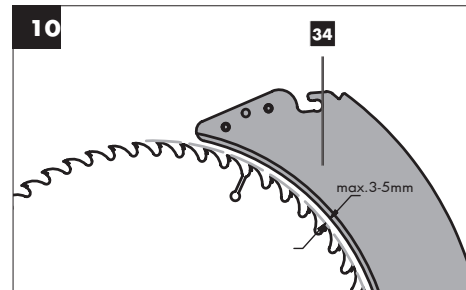
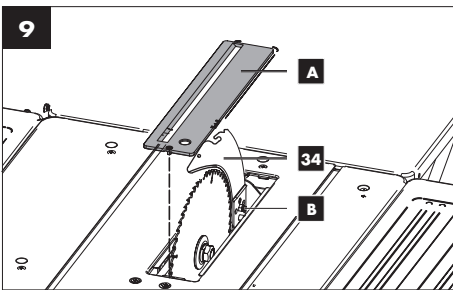
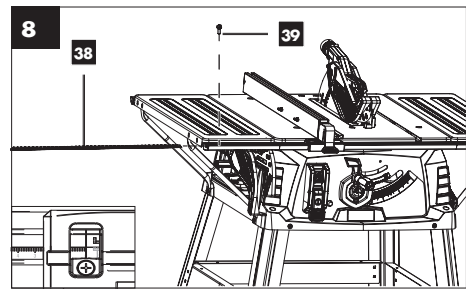
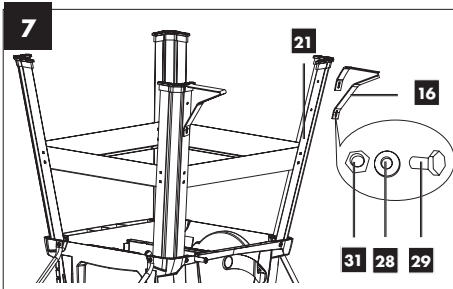
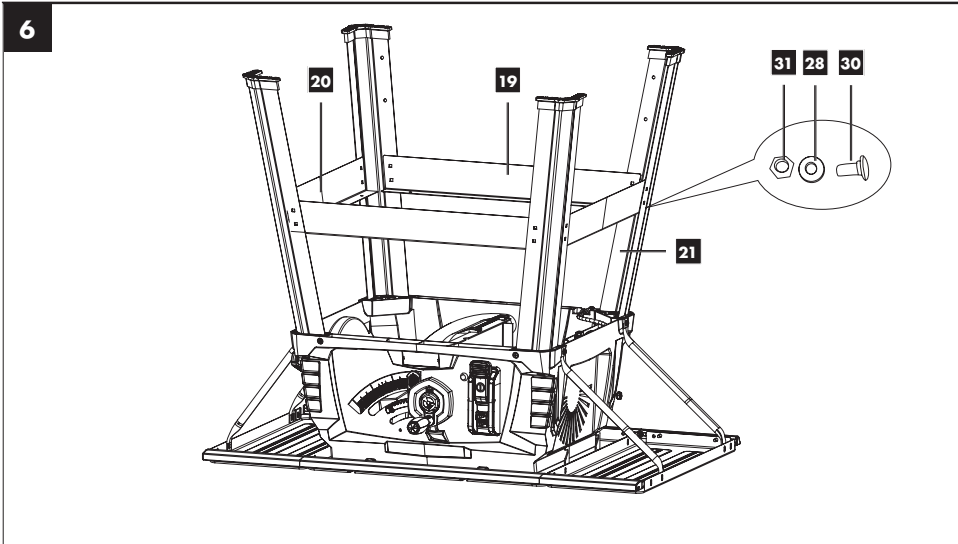

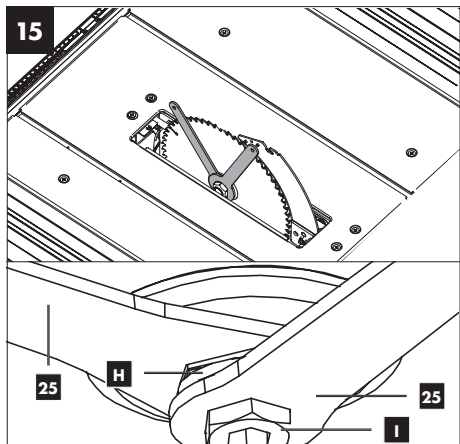
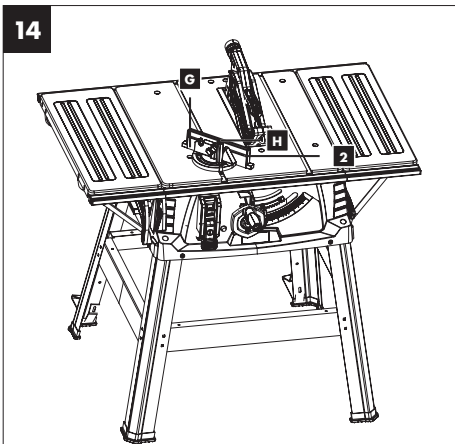
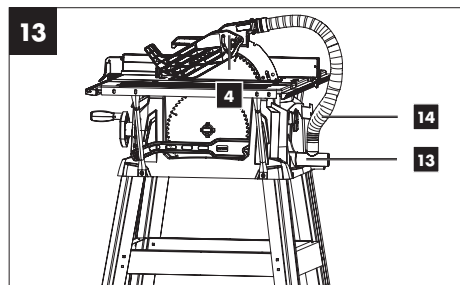
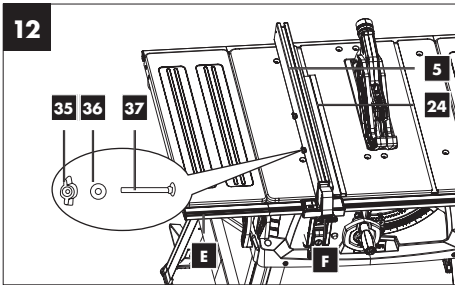
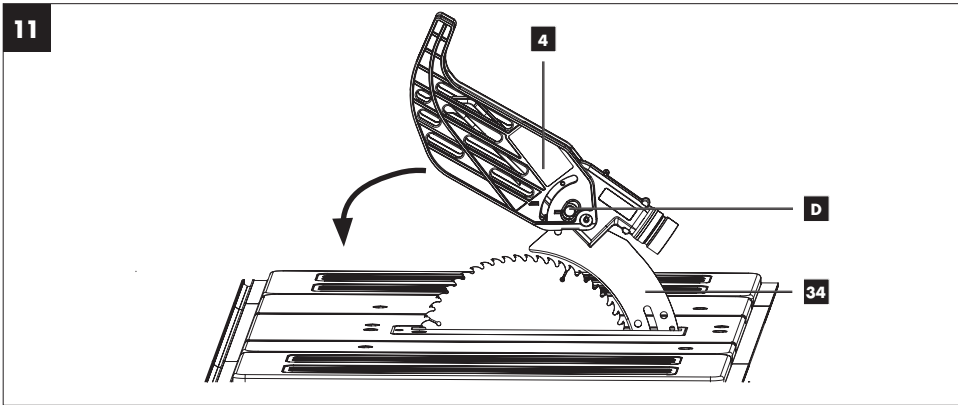

Explanation of Symbols

	This symbol, marking a point of safety, indicates a caution, warning or danger. Ignoring this warning can result in an accident to yourself or others. To limit the risks of injury, fire or electrocution, always follow the recommendations indicated.
	The machine comply with the Australian safety rules and standards.
	Wear eye protection.
	Wear ear protection.
	Wear a dust mask.
	Important! Risk of injury. Never reach into the running saw blade!
	Read through the manual carefully before you work on the power tool.
	Protection class II (Double insulation)
	Warranty period.
	Warranty class
⚠ Attention!	These operating instruction provide places concerning your safety which are marked with this indication.
⚠ Caution!	Failure to follow these instructions may cause light to medium risk of injury!
⚠ Warning!	Failure to follow these instructions may cause danger to life or danger of serious injuries!

I. Introduction

Congratulations on choosing to buy a FERREX® product.

All products brought to you by FERREX® are manufactured to the highest standards of performance and safety, and as part of our philosophy of customer service and satisfaction, are backed by our comprehensive 3 Year Warranty.

We hope you will enjoy using your purchase for many years to come.

Note:

According to the applicable product liability law the manufacturer of this device is not liable for any damages which arise on or in connection with this device in case of:

- improper handling,
- non-compliance with the instructions for use,
- repairs by third party, non-authorized skilled workers,
- installation and replacement of non-original spare parts,
- improper use,
- failures of the electrical system due to the non-compliance with the electrical specifications and the safety standards.

Recommendations:

Read the entire text of the operating instructions prior to the assembly and operation of the device.

These operating instructions are intended to make it easier for you to get familiar with your device and utilise its intended possibilities of use.

The operating instructions contain important notes on how to work safely, properly and economically with your machine and how to avoid dangers, save repair costs, reduce downtime, and increase the reliability and working life of the machine.

In addition to the safety regulations contained herein, you must in any case comply with the applicable regulations of your country with respect to the operation of the machine.

Put the operating instructions in a clear plastic folder to protect them from dirt and humidity, and store them near the machine. The instructions must be read and understood by each operator prior to starting the work. Only persons who have been trained in the use of the machine and have been informed on the related dangers and risks are allowed to use the machine. The required minimum age must be met.

In addition to the safety notes contained in the present operating instructions and the special regulations of your country, the generally recognised technical rules for the operation of machines must be observed.

II. Device description (Fig. 1, 2, 3)

1. Left table extension
2. Transverse stop
3. Saw blade
4. Saw blade guard
5. Parallel stop
6. Right table extension
7. Speed switch
8. On / Off switch
9. Overload switch
10. Locking handle
11. Crank wheel
12. Crank
13. Suction port
14. Suction hose
15. Push stick
16. Tilt protection, 2x
17. Short table support, 2x
18. Long table support, 2x
19. Centre strut, long, 2x
20. Centre strut, short, 2x
21. Leg, 4x
22. Rubber foot, 4x
23. Connection piece, 2x
24. Rail for parallel stop
25. Saw blade spanner, 2x
26. Spanner
27. Allen key
28. Disc
29. Short hexagon screw
30. Carriage bolt
31. Nut
32. Oval head screw
33. Long hexagon screw
34. Riving knife (pre-mounted)
35. Wing nut
36. Big disc
37. Long carriage bolt
38. Scale
39. Screw

III. Unpacking

- Open the packaging and remove the device carefully.
- Remove the packaging material as well as the packaging and transport bracing (if available).
- Check that the delivery is complete.
- Check the device and accessory parts for transport damage.
- If possible, store the packaging until the warranty period has expired.

⚠ ATTENTION! The device and packaging materials are not toys!
Children must not be allowed to play with plastic bags, film and small parts!
There is a risk of swallowing and suffocation!

IV. Intended use

The table saw is designed for the slitting and cross-cutting (only with the cross stop) of all types of timber; plastics, non-ferrous metals, with the exception of magnesium and alloys containing magnesium. The equipment is not to be used for cutting any type of round wood.

The equipment is allowed to be used only for its prescribed purpose. Any other use is deemed to be a case of misuse. The user/operator and not the manufacturer will be liable for any damage or injuries of any kind resulting from such misuse.

The machine is to be operated only with suitable saw blades (HM or CV saw blades). The use of any type of HSS saw blades and cutting discs is prohibited.

An element of the intended use is also the observance of the safety instructions, as well as the assembly instructions and operating information in the operating manual.

Persons who operate and maintain the machine must be familiar with the manual and must be informed about potential dangers.

In addition, the applicable accident prevention regulations must be strictly observed.

Other general occupational health and safety-related rules and regulations must be observed.

⚠ IMPORTANT

When using the equipment, a few safety precautions must be observed to avoid injuries and damage. Please read the complete operating instructions and safety regulations with due care. Keep this manual in a safe place, so that the information is available at all times. If you give the equipment to any other person, hand over these operating instructions and safety

regulations as well. We cannot accept any liability for damage or accidents which arise due to a failure to follow these instructions and the safety instructions.

The manufacturer shall not be liable for any changes made to the machine nor for any damage resulting from such changes.

Even when the machine is used as prescribed it is still impossible to eliminate certain residual risk factors. The following hazards may arise in connection with the machine's construction and design:

- Contact with the saw blade in the uncovered saw zone
- Reaching into the running saw blade (cut injuries)
- Kick-back of workpieces and parts of workpieces
- Saw blade fracturing
- Catapulting of faulty carbide tips from the saw blade
- Damage to hearing if essential ear-muffs are not worn
- Harmful emissions of wood dust when the machine is used in closed rooms

This product is intended for domestic use only and has not been designed for use in commercial, trade or industrial applications. Our warranty will be voided if the equipment is used in commercial, trade or industrial businesses or for equivalent purposes.

V. Safety regulations

General power tool safety regulations

⚠ WARNING: Read all safety warnings, instructions, illustrations and technical data provided with this power tool. Failure to follow the warnings and instructions may result in electric shock, fire and/or serious injury.

Save all warnings and instructions for future reference.

The term "power tool" in the warnings refers to your mains-operated (corded) power tool or battery-operated (cordless) power tool.

1) Work area safety

a) Keep work area clean and well lit. Cluttered or dark areas invite accidents.

b) Do not operate power tools in explosive atmospheres, such as in the

presence of flammable liquids, gases or dust. Power tools create sparks which may ignite the dust or fumes.

- c) Keep children and bystanders away while operating a power tool.** Distractions can cause you to lose control.

2) Electrical safety

- a) Power tool plugs must match the outlet. Never modify the plug in any way. Do not use any adapter plugs with earthed (grounded) power tools.** Unmodified plugs and matching outlets will reduce risk of electric shock.
- b) Avoid body contact with earthed or grounded surfaces, such as pipes, radiators, ranges and refrigerators.** There is an increased risk of electric shock if your body is earthed or grounded.
- c) Do not expose power tools to rain or wet conditions.** Water entering a power tool will increase the risk of electric shock.
- d) Do not abuse the cord. Never use the cord for carrying, pulling or unplugging the power tool. Keep cord away from heat, oil, sharp edges or moving parts.** Damaged or entangled cords increase the risk of electric shock.
- e) When operating a power tool outdoors, use an extension cord suitable for outdoor use.** Use of a cord suitable for outdoor use reduces the risk of electric shock.
- f) If operating a power tool in a damp location is unavoidable, use a residual current device (RCD) protected supply.** Use of an RCD reduces the risk of electric shock.

3) Personal safety

- a) Stay alert, watch what you are doing and use common sense when operating a power tool. Do not use a power tool while you are tired or under the influence of drugs, alcohol or medication.** A moment of inattention while operating power tools may result in serious personal injury.
- b) Use personal protective equipment. Always wear eye protection.** Protective equipment such as a dust mask, non-skid safety shoes, hard hat or hearing protection used for appropriate conditions will reduce personal injuries.
- c) Prevent unintentional starting. Ensure the switch is in the off-position**

before connecting to power source and/or battery pack, picking up or carrying the tool. Carrying power tools with your finger on the switch or energising power tools that have the switch on invites accidents.

- d) Remove any adjusting key or wrench before turning the power tool on.** A wrench or a key left attached to a rotating part of the power tool may result in personal injury.
- e) Do not overreach. Keep proper footing and balance at all times.** This enables better control of the power tool in unexpected situations.
- f) Dress properly. Do not wear loose clothing or jewellery. Keep your hair and clothing away from moving parts.** Loose clothes, jewellery or long hair can be caught in moving parts.
- g) If devices are provided for the connection of dust extraction and collection facilities, ensure these are connected and properly used.** Use of dust collection can reduce dust-related hazards.
- h) Do not let familiarity gained from frequent use of power tools allow you to become complacent and ignore power tool safety principles.** A careless action can cause severe injury within a fraction of a second.

4) Power tool use and care

- a) Do not force the power tool. Use the correct power tool for your application.** The correct power tool will do the job better and safer at the rate for which it was designed.
- b) Do not use the power tool if the switch does not turn it on and off.** Any power tool that cannot be controlled with the switch is dangerous and must be repaired.
- c) Disconnect the plug from the power source and/or remove the battery pack, if detachable, from the power tool before making any adjustments, changing parts of insert tools, or storing power tools.** Such preventive safety measures reduce the risk of starting the power tool accidentally.
- d) Store idle power tools out of the reach of children and do not allow persons unfamiliar with the power tool or these instructions to operate the power tool.** Power tools are dangerous in the hands of untrained users.
- e) Maintain power tools and insert tools. Check for misalignment or binding of moving parts, breakage of parts and any other condition that may affect the power tool's operation. If damaged, have the pow-**

er tool repaired before use. Many accidents are caused by poorly maintained power tools.

- f) Keep cutting tools sharp and clean.** Properly maintained cutting tools with sharp cutting edges are less likely to bind and are easier to control.
- g) Use the power tool, accessories and tool bits etc. in accordance with these instructions, taking into account the working conditions and the work to be performed.** Use of the power tool for operations different from those intended could result in a hazardous situation.
- h) Keep handles and grasping surfaces dry, clean and free from oil and grease.** Slippery handles and grasping surfaces do not allow for safe handling and control of the tool in unexpected situations.

Service

- a) Have your power tool serviced by a qualified repair person using only identical replacement parts.** This will ensure that the safety of the power tool is maintained.

Safety instructions for table saws

Guarding related warnings

- a) Keep guards in place. Guards must be in working order and be properly mounted.** A guard that is loose, damaged, or is not functioning correctly must be repaired or replaced.
- b) Always use saw blade guard, riving knife and for every through-cutting operation.** For through-cutting operations where the saw blade cuts completely through the thickness of the workpiece, the guard and other safety devices help reduce the risk of injury.
- c) Immediately reattach the guarding system after completing an operation (such as rabbeting, dadoing or resawing cuts) which requires removal of the guard and/or the splitter.** The guard help to reduce the risk of injury.
- d) Make sure the saw blade is not contacting the guard, riving knife or the workpiece before the switch is turned on.** Inadvertent contact of these items with the saw blade could cause a hazardous condition.
- e) Adjust the riving knife as described in this instruction manual.** Incorrect spacing, positioning and alignment can make the riving knife ineffective in reducing the likelihood of kickback.

f) For the riving knife to work, they must be engaged in the workpiece.

The riving knife are ineffective when cutting workpieces that are too short to be engaged with the riving knife. Under these conditions a kickback cannot be prevented by the riving knife.

g) Use the appropriate saw blade for the riving knife. For the riving knife to function properly, the saw blade diameter must match the appropriate riving knife and the body of the saw blade must be thinner than the thickness of the riving knife and the cutting width of the saw blade must be wider than the thickness of the riving knife.

Safety information for sawing

a) ⚠ DANGER: Do not place your hands and fingers in the sawing area or close to the saw blade.

A moment of carelessness or a slip could steer your hand towards the saw blade and result in serious injuries.

b) Only guide the workpiece against the rotational direction of the saw blade or cutting tool. Guiding the workpiece in the same direction as the rotational direction of the saw blade above the table can lead to the workpiece and your hand being drawn into the saw blade.

c) When performing longitudinal cuts, never use the mitre stop to guide the workpiece, and when transverse cutting with the mitre stop never additionally use the parallel stop for longitudinal adjustment. Simultaneously guiding the workpiece with the parallel stop and mitre stop increases the probability that the saw blade will jam and kickback will result.

d) When performing longitudinal cuts, always apply the feed force to the workpiece between the stop rail and the saw blade. Use a push rod if the distance between the stop rail and saw blade is less than 150 mm, and a push block if the distance is less than 50 mm. This type of working aid ensures that your hands remain a safe distance from the saw blade.

e) Only use the push rod provided by the manufacturer, or a push rod that has been produced in accordance with instructions. The push rod ensures a sufficient distance between the hand and saw blade.

f) Never use a damaged or partially sawn push rod. A damaged push rod may break and lead to your hand running into the saw blade.

g) Never work “freehand”. Always use the parallel stop or the mitre stop to position and guide the workpiece. “Freehand” means supporting or guiding the workpiece with the hands, rather than using the parallel stop or mitre stop. Free-handed sawing leads to incorrect alignment, jam-

ming and kickback.

- h) Never reach around or over a turning saw blade.** Reaching for a workpiece can lead to accidental contact with the rotating saw blade.
- i) Support long and/or wide workpieces at the rear and/or side of the saw table, so that they remain horizontal.** Long and/or wide workpieces tend to tilt at the edge of the saw table; this leads to a loss of control, jamming of the saw blade and kickback.
- j) Guide the workpiece steadily and evenly. Do not bend or twist the workpiece. If the saw blade jams, switch off the electric tool immediately, unplug the mains plug and remedy the cause of the jam.** If the saw blade is jammed by the workpiece, this can lead to kickback or block the motor.
- k) Do not remove partially sawn material whilst the saw is running.** Partially sawn material can stick between the saw blade and stop rail or in the protective cover, and may draw your fingers into the saw blade during removal. Switch the saw off and wait until the saw blade has come to a standstill, before removing the material.
- l) For longitudinal cuts on workpieces that are thinner than 2 mm, use an additional parallel stop that is in contact with the table surface.** Thin workpieces can wedge under the parallel stop and lead to kickback.

Kickback - causes and corresponding safety instructions

Kickback is a sudden reaction of the workpiece to a catching or jamming saw blade, or a cut created in the workpiece at an angle to the saw blade, or if part of the workpiece becomes jammed between the saw blade and the parallel stop, or another stationary object.

In the majority of cases, with kickback the workpiece is caught by the rear part of the saw blade, lifted off the saw table and thrust in the direction of the operator. Kickback is the result of incorrect or deficient use of the circular table saw. It can be prevented by suitable precautionary measures, as described in the following.

- a) Never stand directly in line with the saw blade. Always stand at the side of the saw blade on which the stop rail is located.** With kickback, the workpiece may be thrust at high speed towards those persons who stand in front of, or in line with the saw blade.
- b) Never reach over or behind the saw blade to pull or support the work-**

piece. This can result in accidental contact with the saw blade, or kickback can lead to your fingers being drawn into the saw blade.

- c) Never hold and push the workpiece against the turning saw blade during sawing.** Pushing the workpiece against the saw blade during sawing will lead to jamming and kickback.
- d) Align the stop rail parallel to the saw blade.**
A stop rail that is not aligned will push the workpiece against the saw blade and create kickback.
- e) With concealed saw cuts (e.g. folds, grooves or slits in the turning process), use a thrust collar to guide the workpiece against the table and stop rail.** Using a thrust collar, you are able to better control the workpiece in the event of kickback.
- f) Apply particular caution when sawing assembled workpieces in areas that are not visible.** The plunging saw blade can saw into objects that could cause a kickback.
- g) Support large panels, in order to avoid the risk of kickback due to a jammed saw blade.** Large panels may bend under their own weight. Panels must be supported in all areas where they overhang the table surface.
- h) Apply particular caution when sawing workpieces that are twisted, knotted or warped, or that do not have a straight edge that can be used to guide them with a mitre stop or along a stop rail.** A twisted, knotted or warped workpiece is unstable and results in incorrect alignment of the kerf with the saw blade, jamming and kickback.
- i) Never saw multiple workpieces stacked on top of each other, or one behind the other.** The saw blade could engage in one or more parts and result in kickback.
- j) If you wish to restart a saw, the saw blade of which is inserted in a workpiece, centre the saw blade in the sawing gap so that the saw teeth are not hooked in the workpiece.** If the saw blade is jammed, it can lift the workpiece and cause kickback when the saw is restarted.
- k) Always keep saw blades clean, sharp and sufficiently set. Never use warped saw blades or saw blades with cracked or broken teeth.** Sharp and correctly set saw blades minimise jamming, blocking and kickback.

Safety instructions for the operation of circular table saws

- a) **Switch off the circular table saw and disconnect it from the power supply before removing the table insert, changing the saw blade, implementing settings on the riving knife or the saw blade protective cover, and if the machine is left unattended.** Precautionary measures serve to prevent accidents.
- b) **Never leave the circular table saw running unattended. Switch off the electric tool and do not leave it until it has come to a complete standstill.** An unattended running saw poses an uncontrolled risk.
- c) **Set up the circular table saw in a location that is level and well ventilated, and where it can stand safely and remain balanced. The installation site must provide sufficient space for easily handling the size of your workpieces.** Disorganised and unlit working areas, and uneven, slippery floors may lead to accidents.
- d) **Regularly remove chips and sawdust from beneath the saw table and/or from the dust extraction system.** Accumulated sawdust is flammable and can self-ignite.
- e) **Secure the circular table saw.** If a circular table saw is not secured correctly, it can move or topple.
- f) **Remove the adjustment tools, wood residues, etc. from the circular table saw before switching it on.** Deflections and possible jams could be dangerous.
- g) **Always use the right size of saw blade and an appropriate location hole (e.g. diamond-shaped or round).** Saw blades that do not fit with the mounting parts of the saw will run out-of-centre and result in a loss of control.
- h) **Never use damaged or incorrect saw blade mounting materials, such as flanges, washers, screws or nuts.** These saw blade mounting materials have been specially designed for your saw, for optimum performance and operational safety.
- i) **Never stand on the circular table saw and do not use it as a step stool.** Serious injuries can arise if the electric tool topples or if you accidentally come into contact with the saw blade.
- j) **Make sure that the saw blade is mounted in the correct direction of rotation. Do not use grinding discs or wire brushes with the circular table saw.** Incorrect assembly of the saw blade or the use of accessories that have not been recommended can result in serious injuries.

Safety instructions for handling saw blades

1. Only use tools which you know how to handle.
2. Pay attention to the maximum speed. The maximum speed stated on the tool being used must not be exceeded. Keep within the speed range if one is specified
3. Note the direction of rotation of the motor and saw blade.
4. Do not use any insertion tools with cracks. Sort out cracked insertion tools. Repairs are not permitted.
5. Clean grease, oil and water off of the clamping surfaces.
6. Do not use any loose reducing rings or bushes to reduce holes on circular saw blades.
7. Make sure that fixed reducer rings for securing the insertion tool have the same diameter and have at least 1/3 of the cutting diameter.
8. Make sure that fixed reducer rings are parallel to each other.
9. Handle the tools used with care. It is best to store these in their original packaging or special containers. Always wear protective gloves to improve your grip and further reduce the risk of injury.
10. Before using any of the tools, ensure that all protective devices are correctly attached.
11. Before use, ensure that all of the tools used by you full the technical requirements of this power tool and are properly attached.
12. The saw blade supplied should only be used for sawing wood and never for working metal.
13. Use the saw blade intended for the material to be processed.
14. Only use a saw blade with a diameter which is marked on the saw.
15. Only use saw blades marked with a speed equal to or higher than the speed marked on the power tool.
16. Only use saw blades recommended by the manufacturer which, if intended for cutting wood or similar materials, comply with EN 847-1.
17. Wear suitable personal protective equipment, such as:
 - hearing protection;
 - protective gloves when handling saw blades.
18. Only use saw blades recommended by the manufacturer that comply with EN 847-1. Warning! When changing the saw blade, make sure that the cutting width is not smaller and that the thickness of the saw blade is not greater than the thickness of the splitter.
19. When sawing timber, avoid overheating the saw teeth.

Residual Risks

This power tool has been constructed in accordance with the latest technology and the generally recognised safety regulations. Nevertheless, it is possible that individual residual risks may occur during operation.

- Electrical hazard if improper electrical connection cables are used.
- In addition, concealed residual risks may be present in spite of all the precautions that have been taken.
- Residual risks can be minimised by observing the „Safety instructions“ and „Intended use“, as well as the operating instructions.
- Do not put any unnecessary stresses on the machine: excessive pressure during sawing will quickly damage the saw blade. This may result in a reduction in the performance of the machine, as well as a reduction in the cutting accuracy.
- Avoid switching the machine on by accident: when inserting the plug into the socket, the power button must not be pressed.
- Use the tool which is recommended in this manual. This will ensure the optimal performance of your saw.
- Keep your hands away from the working area when the machine is in operation.
- Before you carry out any adjustments or servicing work, turn the device off and remove the mains plug.

⚠ WARNING

This electric tool generates an electromagnetic field during operation. This field can impair active or passive medical implants under certain conditions. In order to prevent the risk of serious or deadly injuries, we recommend that persons with medical implants consult with their physician and the manufacturer of the medical implant prior to operating the electric tool.

VI. Technical data

AC motor	220-240 V~ 50 Hz
Performance	2000 Watt
Operating mode	S6 40%
Idle speed n_0	3200 / 5000 min ⁻¹
Saw blade	∅ 254 x ∅ 30 mm
Number of teeth	48
Riving knife thickness	2.5 mm
Minimum size work piece WxLxH	10 x 50 x 1 mm
Table size	575 x 555 mm
Table with extension	575 x 1005 mm
Cutting height max. 45°	65 mm
Cutting height 90°	85 mm
Saw blade swivel	-2 to +45° left

NOISE VALUES

The total noise values were determined in accordance with EN 62841.

Sound pressure level L_{pA}	96.8 dB(A)
Uncertainty K_{pA}	3 dB
Sound power level L_{WA}	109.8 dB(A)
Uncertainty K_{WA}	3 dB

Wear hearing protection.

The effects of noise can cause a loss of hearing. Total vibration values (vector sum - three directions) determined in accordance with EN 62841.

NOTE: The indicated sound levels have been determined according to a standardized testing procedure and can be used to compare different power tools with each other. Furthermore, these values are suitable to evaluate the loads that sounds can cause for the user in advance.

ATTENTION: Depending on how you will use the power tool, the actual values may deviate from the indicated values. Take measures to protect yourself from noise pollution. In this process it is important to take the complete sequence of operation into account. This also includes moments during which the power tool operates without load and moments during which it is turned off. Suitable measures comprise amongst other things regular maintenance and service of the power tool and the insertion tools, regular breaks and the appropriate planning of the sequences of operation.

VII. Before starting the equipment

- Open the packaging and remove the device carefully.
- Remove the packaging material as well as the packaging and transport bracing (if available).
- Check that the delivery is complete.
- Check the device and accessory parts for transport damage.
- If possible, store the packaging until the warranty period has expired.

⚠ ATTENTION

The device and packaging materials are not toys! Children must not be allowed to play with plastic bags, film and small parts! There is a risk of swallowing and suffocation!

- The equipment must be securely installed, i.e. bolted down on a workbench, base frame or similar. To do this, use the holes located on the inside of the frame feet.
- All covers and safety devices have to be properly fitted before the equipment is switched on.
- It must be possible for the blade to run freely.
- When working with wood that has been processed before, watch out for foreign bodies such as nails or screws, etc.
- Before you switch ON the machine, check that the saw blade is fitted correctly. Moving parts must run smoothly.
- Before you connect the equipment to the power supply make sure the data on the rating plate are identical to the mains data.

VIII. Assembly

Risk of injury!

Incorrectly assembling the table saw can result in serious injury.

- Before start-up, assemble the table saw properly and completely, including all covers and safety devices.
- Do not in any case insert the mains plug in the socket until you have completed assembly

Hexagon screws must each be inserted from outside inwards. During assembly nuts and screws must only be tightened until hand-tight, so that they cannot fall out. If you tighten the nuts and screws fully before final assembly, the circular table saw cannot be erected in a correct and stable manner.

Installing the table extension (Fig. 4)

1. Turn the saw table over and place it on the floor.
2. Plug the connection pieces (23) into the front rail of the table saw.
3. Mount both table extensions (1 / 6) loosely on the saw table with four short hexagon screws (29), four discs (30) and four nuts M6 (31). To do so, use the corresponding holes drilled into the saw table.
4. Fix all screws with the spanner (26).

Mounting the frame (Fig. 5 / 6)

Only tighten all screws at this mounting step by hand.

1. Push one rubber foot (22) onto each leg (21).
2. Push the four legs (21) in the slots of the table saw frame.
3. Connect the short table supports (17) and long table supports (18) with the base frame and left/right table extension (1/6). Use for this four short hexagon screws (29), eight discs (28), four long hexagon screws (33) and four nuts (31).
4. Secure the four legs (21) with the four oval head screw (32) and four disc (28) at the front and the back side of the table saw with a screwdriver (not included).
5. Mount the long centre struts (19) and the short centre struts (20) at the legs (21) with 16 carriage bolts (30), 16 discs (28) and 16 nuts (31).

Mounting the tilt protection (Fig. 7)

1. Assemble the tilt protection (16) at the legs (21) at the backside of the table saw by using four short hexagon screws (29), four discs (28) and four nuts (31).

Inserting the scale (Fig. 8)

1. Turn the saw blade to the maximum position out of the saw table by turning the crank (12) counter-clockwise until it reaches the stop.
2. Push the scale (38) into the guide groove of the guide rail until it is approximately centred.
3. Position the parallel stop (5) with open eccentric lever (F) on the guide rail on the saw table such that it have contact with the saw blade (3).
4. Secure this position by pressing the eccentric lever (F) fully downwards.
5. Align the zero point of the scale (38) with the sight glass of the parallel stop (5) and secure this position with the two screws (39).

Mounting/Adjusting the riving knife (Fig. 9-10)

Risk of injury!

Unintended activation of the table saw and improper handling of the saw blade could result in serious injury.

- Always pull the mains plug out of the socket before you make any adjustments to the table saw's settings.
 - Always wear protective gloves when handling the saw blade or working in its direct vicinity.
- Check the riving knife (34) every time after you change the saw blade and realign it if necessary.

1. Remove the table insert (A) with a screwdriver (not included).
2. Turn the saw blade to the maximum position out of the saw table, by turning the crank (12) anti-clockwise until it reaches the stop.
3. Loosen the clamping screw (B) with the spanner (26).
4. Lift the riving knife (34) and put it on the holder.
5. Make sure the riving knife (34) has a distance to the saw blade is 3-5 mm at all points.
6. Secure the riving knife by tightening the clamping screw (B) again clockwise.
7. Insert the table insert (A) in the saw table again and fix it by using a screwdriver (not included).

Mounting/removing the saw blade guard (Fig. 11)

1. Position the saw blade guard (4) onto the rear slot of the riving knife (34).
2. Lower the saw blade guard (4), press the button (D) and slide the coach bolt until the coach bolt engages in the opening provided, put the opening of the coach bolt into the front slot, then loosen the button(D). Keep the sliding parts of blade cover dropped off free.

Mounting the parallel stop (Fig. 12)

1. Insert the long carriage bolt (37) into the parallel stop (5) and secure it with the big disc (36) and wing nut (35).
2. Slide the rail for parallel stop (24) onto the parallel stop (5), such that the two long carriage bolts (37) slides into the guide groove of the rail for parallel stop (24).
3. Secure the rail for parallel stop (24) on the parallel stop (5) by tightening the two wing nuts (35).
4. Mount the parallel stop (5) on the guide rail (E).
5. In order to secure the parallel stop (5) in the desired position, press the eccentric lever (F) down fully.

Connecting the extraction device (Fig. 13)

A normal household vacuum cleaner is **not** a suitable extraction device.

1. Connect the suction hose (14) with the suction port (13) and the the saw blade guard (4).
2. Connect the suction hose of a suitable shavings extractor (e.g. a multi-purpose vacuum cleaner) to the suction port (13) and secure it with a hose clamp.

IX. Setup

Setting the cutting depth (Fig. 1)

Using the crank (12), rotate the saw blade (3) out of the saw table or lower the saw blade into the table saw. In this way, you can set the desired cutting depth.

- Turn the crank (12) anti-clockwise: increase the cutting depth
- Turn the crank (12) clockwise: reduce the cutting depth

Setting the cutting angle (Fig. 1)

1. Loosen the locking handle (10).
2. Use the crank wheel (11) to set the desired cutting angle on the angle scale.
3. Lock the locking handle (10) to fasten the saw blade (3) at the required angle.

Change the side of the parallel stop (Fig. 12)

1. Unscrew the wing nuts (35) fully.
2. Remove the rail for parallel stop (24) with the big discs (36) and the long carriage bolts (37) and replace the bolts on the other side of the parallel guide.
3. Slide the rail for parallel stop (24) onto the parallel stop (5), such that the two long carriage bolts (37) slides into the guide groove of the rail for parallel stop (24).
4. In order to secure the stop rail on the parallel stop, turn the wing nuts (35) to tighten them again.

Setting the transverse stop (Fig. 14)

Do not push the stop rail (G) too far towards the saw blade (3). There should be approx. 2 cm of space between the stop rail and saw blade.

5. Push the transverse stop (2) into one of the two guide slots on the saw table.
6. Loosen the handle (H) and turn the cross guide until you have set it at the required angle.
7. Retighten the handle (H).

X. Operation

⚠ WARNING! Risk of injury!

Improper assembly of the table saw can result in serious injury.

- Before start-up, assemble the table saw properly and completely.
- Before switching the table saw on, make sure the saw blade is correctly mounted and that mobile parts can move freely.

After switching on the saw, you must wait until the saw blade (3) has reached the maximum speed before you perform the cut.

Switching the table saw on and off (Fig. 1 / Pos. 8)

- To switch on the table saw, lift the cover flap (8) and press the green operating switch I. The motor will start.
- To switch the table saw off, push the cover flap (8) to switch off.

Changing the speed (Fig. 1)

The table saw has 2 speed ranges:

- To operate the saw at a speed of 3200 rpm (non-ferrous metals), set the speed switch (7) to Slow-position.
- To operate the saw at a speed of 5000 rpm (wood), set the speed switch (7) to Fast-position.

Sawing with the table saw

⚠ WARNING! Risk of injury!

Improperly handling the table saw poses a risk of serious injury.

- When performing lengthwise cuts, do not stand directly in front of the table saw, instead stand diagonal to the cutting line.
- When performing bevel cuts, always use the parallel guide.
- Use a push stick or a push block to safely push the workpiece by the saw blade. Immediately replace a damaged or worn push stick.
- Secure long workpieces so that they do not tip over at the end of the cut. Use a roller stand for this, for example.
- After switching on the table saw, wait until the saw blade has reached its maximum speed before you perform the cut.
- Only operate the table saw with an extraction device.
- Each time after making a new setting, perform a test cut to check the set dimensions.
- Check and clean the suction channels regularly.

Performing lengthwise cuts

A lengthwise cut is applied to cut a workpiece lengthwise. Push an edge of the workpiece against the parallel stop (5) with the flat side on the saw table.

1. Lower the saw blade guard (4) onto the saw table. The saw blade guard is pushed up by the workpiece while sawing.
2. Switch on the dust extractor first and then the table saw.
3. With your fingers closed, place your hands flat on the workpiece and push it along the parallel guide into the saw blade (3).
4. Guide the workpiece laterally just to the front edge of the saw blade guard with your left hand.
5. Always push the workpiece up to the end of the riving knife (34) using the push stick (15).

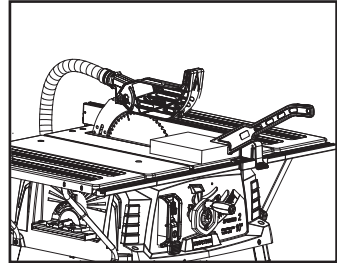

Performing bevel cuts

1. Set the saw blade to the desired angle.
2. Set the parallel guide corresponding to the width and height of the workpiece.
3. Lower the saw blade guard (4) onto the saw table.
4. Perform the cut corresponding to the width of the workpiece.

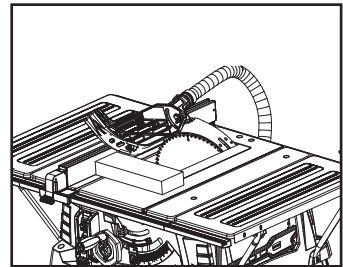

Performing cross cuts

⚠ **WARNING! Risk of injury!**

Improperly handling the table saw poses a risk of serious injury.

- Always take hold of the guided workpiece and never of the unguided work piece that is being cut off.
 - Always push the cross guide forward until the workpiece has been cut through completely.
1. Set the transverse stop (2) as necessary. If the saw blade is also to be set at an angle, push the transverse stop into the right-hand side groove to prevent your hand and the transverse stop from coming into contact with the saw blade guard.
 2. Lower the saw blade guard onto the saw table. The saw blade guard is pushed up by the workpiece while sawing.
 3. Firmly push the workpiece against the transverse stop.
 4. Switch on the dust extractor first and then the table saw.
 5. To perform a cut, push the cross guide and the workpiece in the direction of the saw blade.

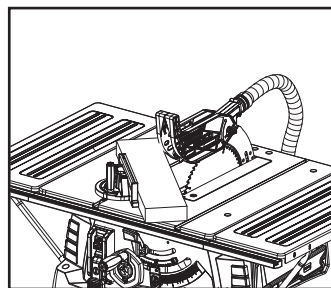

Cutting narrow workpieces

Be absolutely sure to use the push stick (15) when performing lengthwise cuts for workpieces with a width of under 150 mm. For shorter workpieces, the push stick must be used at the beginning of the cutting process.

1. Adjust the parallel stop to the desired width.
2. With your fingers closed, place your hands flat on the workpiece and push it along the parallel stop into the saw blade (3).
3. Always push the workpiece up to the end of the riving knife (34) using the push stick (15).

For lengthwise cuts to very narrow workpieces with a width of 50 mm or less, a push block must be used (not included in the package contents).

1. Adjust the parallel stop to the desired width.
2. Push the workpiece with the push block against the stop rail and push the workpiece to the end of the splitting wedge using the push stick.

Always replace cracked push blocks on a timely basis.

Cutting particle boards

- To prevent raw edges when cutting particle boards, do not set the saw blade higher than 5 mm above the workpiece thickness.

When you are finished cutting

1. First turn the table saw off and then the dust extractor. The saw blade will continue to rotate for some time.
2. Remove the cutting waste from the saw blade when the saw blade returns to the resting position.
3. Disconnect the table saw from the power supply by pulling the mains plug out of the socket.
4. Let the table saw cool off completely.

Releasing the overload protection

This table saw is equipped with overload protection. If the motor has overloaded, the overload switch automatically deactivates it to protect the table saw from overheating.

1. If the overload protection has been activated, switch the table saw off.
2. Wait until the engine has cooled down.
3. Press the overload switch (9) and switch the table saw on.

Removing jammed material

⚠ WARNING! Risk of injury!

Incorrect handling of the table saw poses a risk of serious injury.

- Immediately switch the table saw off and pull the mains plug out of the socket if the saw blade catches in the workpiece or any other blockages occur.
- Use protective gloves. Do not touch the saw blade with your bare hands.

Changing the saw blade (Fig. 9/15)

⚠ WARNING! Risk of injury!

Incorrect handling of the table saw poses a risk of serious injury.

- Ensure that the table saw is not connected to the mains supply.
 - Use protective gloves. Do not touch the saw blade with your bare hands.
1. Turn the saw blade to the maximum position out of the saw table.
 2. Remove the saw blade guard (4) from the riving knife (34).
 3. Remove the table insert (A) with a screwdriver (not included).
 4. Make sure that the angle adjustment of the saw blade is set to 0°.
 5. Place the saw blade spanner (25) on the saw blade fange (H) and one spanner (25) at the fixing nut (I).

6. Turn the fixing nut (I) anticlockwise to undo the fixing nut (I).
7. Hold the saw blade carefully with one hand and remove the fixing nut and outer saw blade flange (H) from the drive shaft.
8. Now remove the saw blade from the drive shaft and carefully draw it up and out of the saw table.
9. Clean the external and internal saw blade flange carefully, before fitting a new saw blade.
10. Place a new saw blade on the drive shaft. Observe the rotational direction: The cutting angle of the teeth must point in the running direction (forwards). The running direction is usually also marked on the saw blade.
11. Fit the external saw blade flange back on the drive shaft. Ensure the correct alignment of the outer saw blade flange.
12. Screw the fixing nut tight onto the drive shaft with the hand.
13. Carefully turn the saw blade in the running direction: It must be precisely centred and must not “wobble”. Check that the saw blade and external saw blade flange are sitting correctly and align the parts once more, if the saw blade is not precisely centred.
14. Tighten the fixing nut (I) with the saw blade spanner (25)
15. Mount the riving knife, table insert and saw blade guard.

XI. Transport

- Turn off the table saw before any transport and disconnect it from the power supply.
- Lower the saw blade (3) as far as possible.
- Carry the table saw with both hands by lifting it by the fixed saw table. Never use the table width extension to carry the power tool.
- Protect the table saw from knocks, bumps and strong vibrations, such as during transport in vehicles.
- Secure the table saw against overturning and sliding.
- Never use the safety devices for handling or transporting purposes.

XII. Maintenance

⚠ **Warning!** Prior to any adjustment, maintenance or service work disconnect the mains power plug!

General maintenance measures

Keep all safety devices, air vents and the motor housing free of dirt and dust as far as possible. Wipe the equipment with a clean cloth or blow it down with compressed air at low pressure.

We recommend that you clean the equipment immediately after you use it.

Clean the equipment regularly with a damp cloth and some soft soap. Do not use cleaning agents or solvents; these may be aggressive to the plastic parts in the equipment. Ensure that no water can get into the interior of the equipment.

In order to extend the service life of the tool, oil the rotary parts once monthly. Do not oil the motor.

Brush inspection

In case of excessive sparking, have the carbon brushes checked only by a qualified electrician. **Important!** The carbon brushes should not be replaced by anyone but a qualified electrician.

XIII. Storage

Clean the electrical power tool as described in the section "General maintenance measures".

Store the electrical power tool and its accessories in a dark, dry, frost-free and well ventilated place out of reach from children. The ideal storage temperature is between 10 and 30°C.

Keep the operating instructions with the power tool.

⚠ **NOTE!** Observe these operating instructions to check the power tool for possible for wear and damage before re-using it.

XIV. Electrical connection

The electrical motor installed is connected and ready for operation. The connection complies with the applicable VDE and DIN provisions. The customer's mains connection as well as the extension cable used must also comply with these regulations.

Important information

In the event of an overloading the motor will switch itself off. After a cool-down period (time varies) the motor can be switched back on again.

Damaged electrical connection cable

The insulation on electrical connection cables is often damaged.

This may have the following causes:

- Passage points, where connection cables are passed through windows or doors
- Kinks where the connection cable has been improperly fastened or routed
- Places where the connection cables have been cut due to being driven over
- Insulation damage due to being ripped out of the wall outlet
- Cracks due to the insulation ageing

Such damaged electrical connection cables must not be used and are life-threatening due to the insulation damage.

Check the electrical connection cables for damage regularly. Make sure that the connection cable does not hang on the power network during the inspection.

Electrical connection cables must comply with the applicable VDE and DIN provisions. Only use connection cables with the marking "H05VV-F".

The printing of the type designation on the connection cable is mandatory.

If the replacement of the supply cord is necessary, this has to be done by the manufacturer or his agent in order to avoid a safety hazard.

AC motor:

- The mains voltage must be 220-240 V ~.
- Extension cables up to 25 m length must have a cross section of 1.5 mm².

Connections and repairs of electrical equipment may only be carried out by an electrician.

Please provide the following information in the event of any enquiries:

- Type of current for the motor
- Machine data - type plate
- Motor data - type plate

XV. Disposal and recycling

The equipment is supplied in packaging to prevent it from being damaged in transit. The raw materials in this packaging can be reused or recycled. The equipment and its accessories are made of various types of material, such as metal and plastic. Defective components must be disposed of as special waste. Ask your dealer or your local council.

XVI. Troubleshooting

Fault	Possible cause	Remedy
Saw blade is loose after the motor is switched off	Fixing nut not tight enough	Tighten fixing nut with right-hand thread
Motor does not start	a) Mains fuse blown	a) Check mains fuse
	b) Extension cable defective	b) Replace extension cable
	c) Connections to the motor or switch not OK	c) Commission check by an electrician
	d) Motor or switch defective	d) Commission check by an electrician
Motor turning sense incorrect	a) Capacitor defective	a) Commission check by an electrician
	b) Incorrect connection	b) Have an electrician transpose the wall plug poles
Motor does not supply power, protection is tripped	a) Cross section of the extension cable insufficient	a) See electrical connection
	b) Overload due to blunt saw blade	b) Replace saw blade
Burn areas at the cutting surface	a) Blunt saw blade	a) Have saw blade sharpened (only by an authorised sharpening specialist) or change it
	b) Incorrect saw blade	b) Replace saw blade



FERREX®

TABLE SAW



Warranty Details

REGISTER YOUR PURCHASE AT www.aldi.com.au/en/about-aldi/product-registration/ TO KEEP UP-TO-DATE WITH IMPORTANT PRODUCT INFORMATION

The product is guaranteed to be free from defects in workmanship and parts for a period of 36 months from the date of purchase. Defects that occur within this warranty period, under normal use and care, will be repaired, replaced or refunded at our discretion. The benefits conferred by this warranty are in addition to all rights and remedies in respect of the product that the consumer has under the Competition and Consumer Act 2010 and similar state and territory laws.

Our goods come with guarantees that cannot be excluded under the Australian Consumer Law. You are entitled to a replacement or refund for a major failure and for compensation for any other reasonably foreseeable loss or damage. You are also entitled to have the goods repaired or replaced if the goods fail to be of acceptable quality and the failure does not amount to a major failure.

AFTER SALES SUPPORT

  1300 855 831

 support@scheppach.com.au

MODEL:DX254TS PRODUCT CODE: 702192 09/2020

3

YEAR WARRANTY



FERREX®

TABLE SAW

Repair and Refurbished Goods or Parts Notice

Unfortunately, from time to time, faulty products are manufactured which need to be returned to the Supplier for repair.

Please be aware that if your product is capable of retaining user-generated data (such as files stored on a computer hard drive, telephone numbers stored on a mobile telephone, songs stored on a portable media player, games saved on a games console or files stored on a USB memory stick) during the process of repair, some or all of your stored data may be lost.

We recommend you save this data elsewhere prior to sending the product for repair.



You should also be aware that rather than repairing goods, we may replace them with refurbished goods of the same type or use refurbished parts in the repair process.

Please be assured though, refurbished parts or replacements are only used where they meet ALDI's stringent quality specifications.

If at any time you feel your repair is being handled unsatisfactorily, you may escalate your complaint. Please telephone us on 1300 855 831 or write to us at:

RossMac Pty. Ltd.
P.O. Box 261, Essendon North, Victoria, 3041
1300 855 831
support@scheppach.com.au

AFTER SALES SUPPORT

  1300 855 831

 support@scheppach.com.au
MODEL:DX254TS PRODUCT CODE: 702192 09/2020



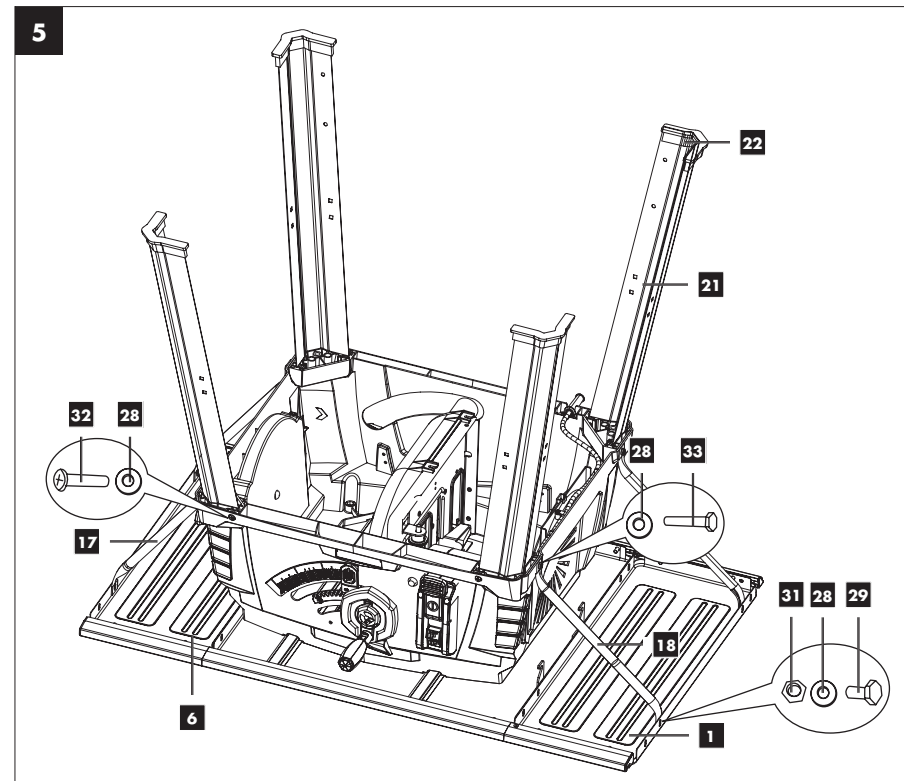
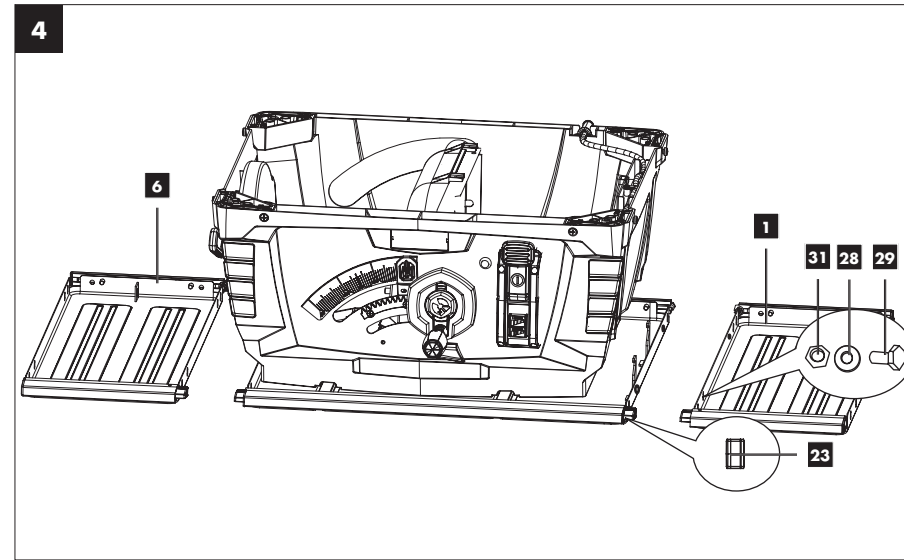
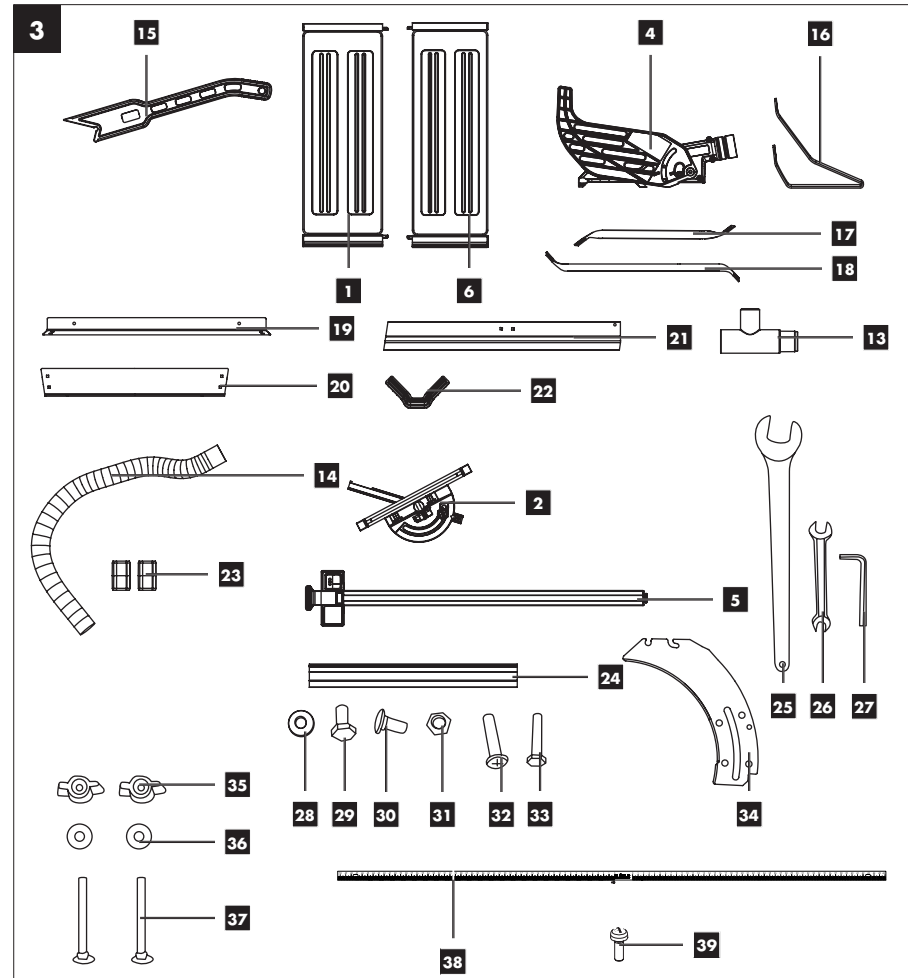

Contents of Box

- 1x Table Saw
- 1x Blade guard
- 1x Push stick
- 1x Rip fence (pre-assembled)
- 1x Under frame
- 2x Saw blade spanner
- 2x Extension table
- 1x Multipurpose TCT blade 48T
- Warranty Certificate
- Manual