



Spend a little Live a lot



Spend a little Live a lot

User Manual

Contents

- Details04
- Contents of box06
- Handling pictures07
- Explanation of the symbols on the equipment09
- Introduction10
- Layout11
- Scope of delivery12
- Intended use12
- Safety regulations13
- Before starting the equipment19
- Assembling and operation20
- Technical data25
- Transport26
- Maintenance26
- Storage26
- Electrical connection27
- Disposal and recycling28
- Troubleshooting28
- Warranty Details29
- Repair and Refurbished Goods or Parts Notice30



1700W SLIDING MITRE SAW



Vers.No. 190107

Original operating manual

ALDI guarantees that our exclusive brand products are developed to our stringent quality specifications. If you are not entirely satisfied with this product, please return it to the nearest ALDI store within 60 days from the date of purchase, for a full refund or replacement, or take advantage of our after sales support by calling the supplier's Customer Service Hotline.

AUS

Made in China
WORKZONE TITANIUM® is a registered trademark of ALDI Stores
DISTRIBUTED BY:
ALDI STORES
1 SARGENTS ROAD
MINCHINBURY NSW 2770
www.aldi.com.au

AFTER SALES SUPPORT	53666	W ²
AUS 1300 855 831		
support@scheppach.com.au		
MODEL: HM80MP	06/2019	

5

**YEARS
WARRANTY**

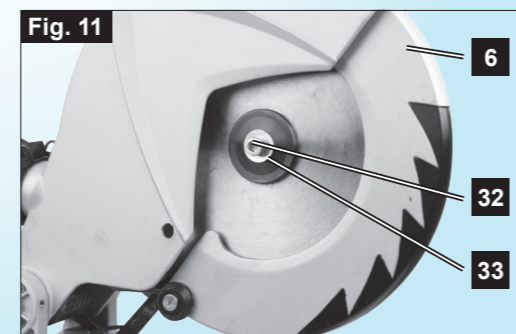
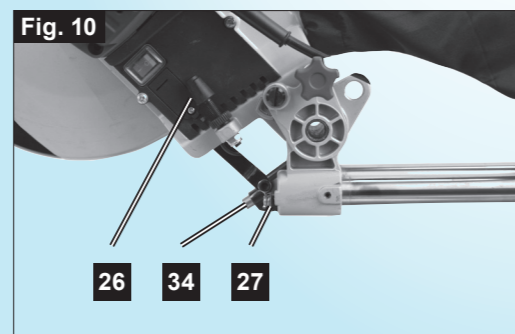
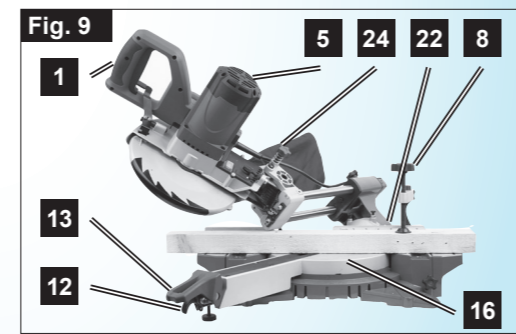
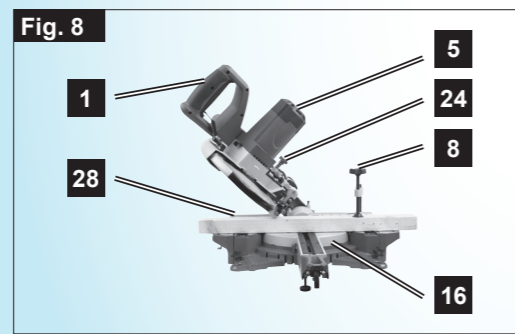
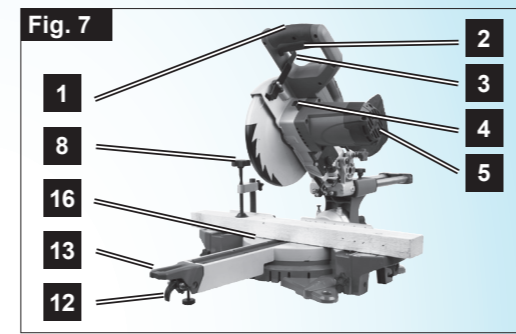
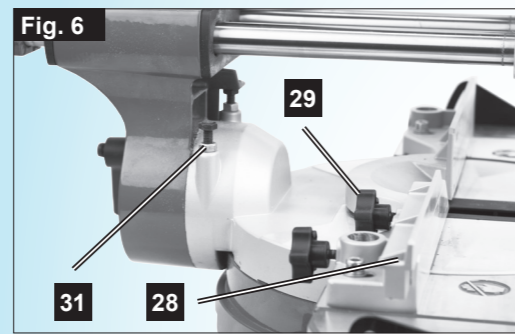
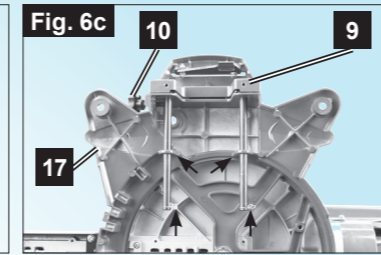
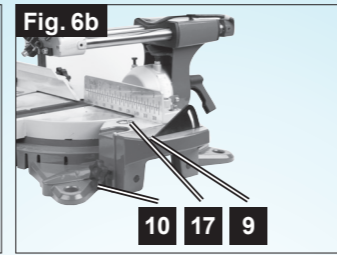
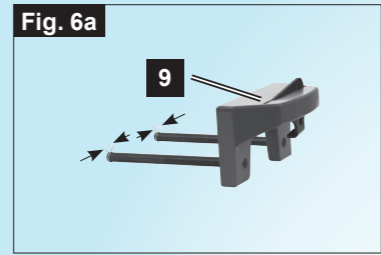
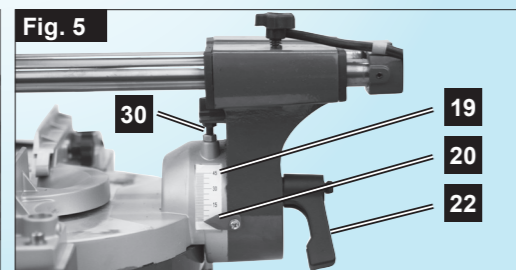
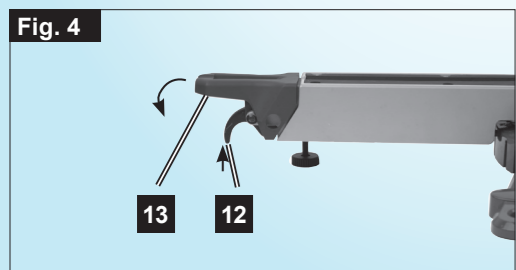
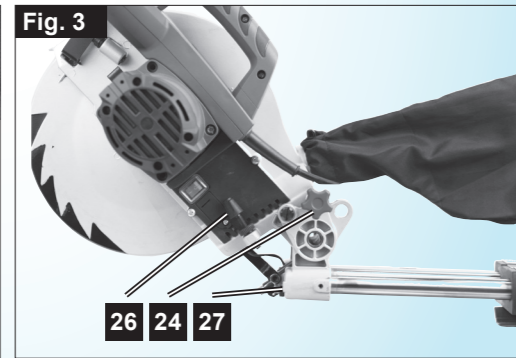
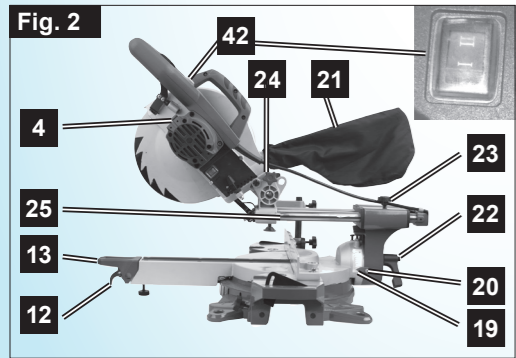
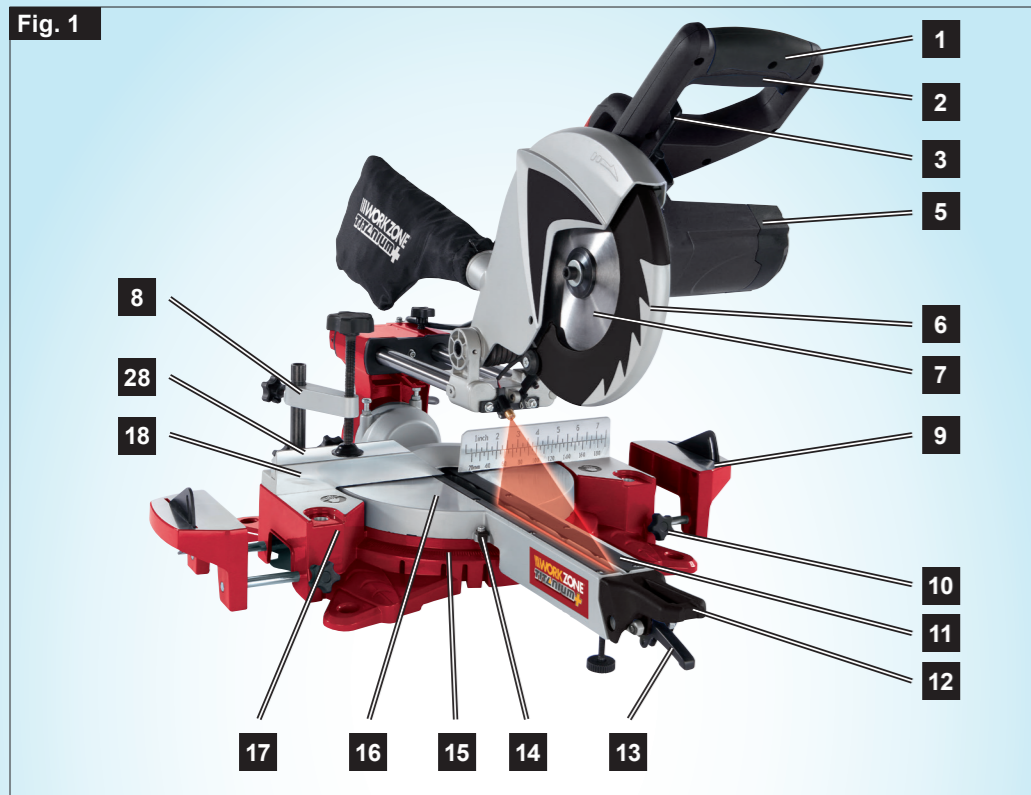

Contents of Box

- 1 1 x Sliding Mitre saw
- 2 1 x Clamping device
- 3 2 x Workpiece support
- 4 1 x Dustbag
- 5 1 x Allen key
- 6 3 x LR44 Battery --- (pre-installed)
- 7 1 x Instruction manual
- 8 1 x Warranty card

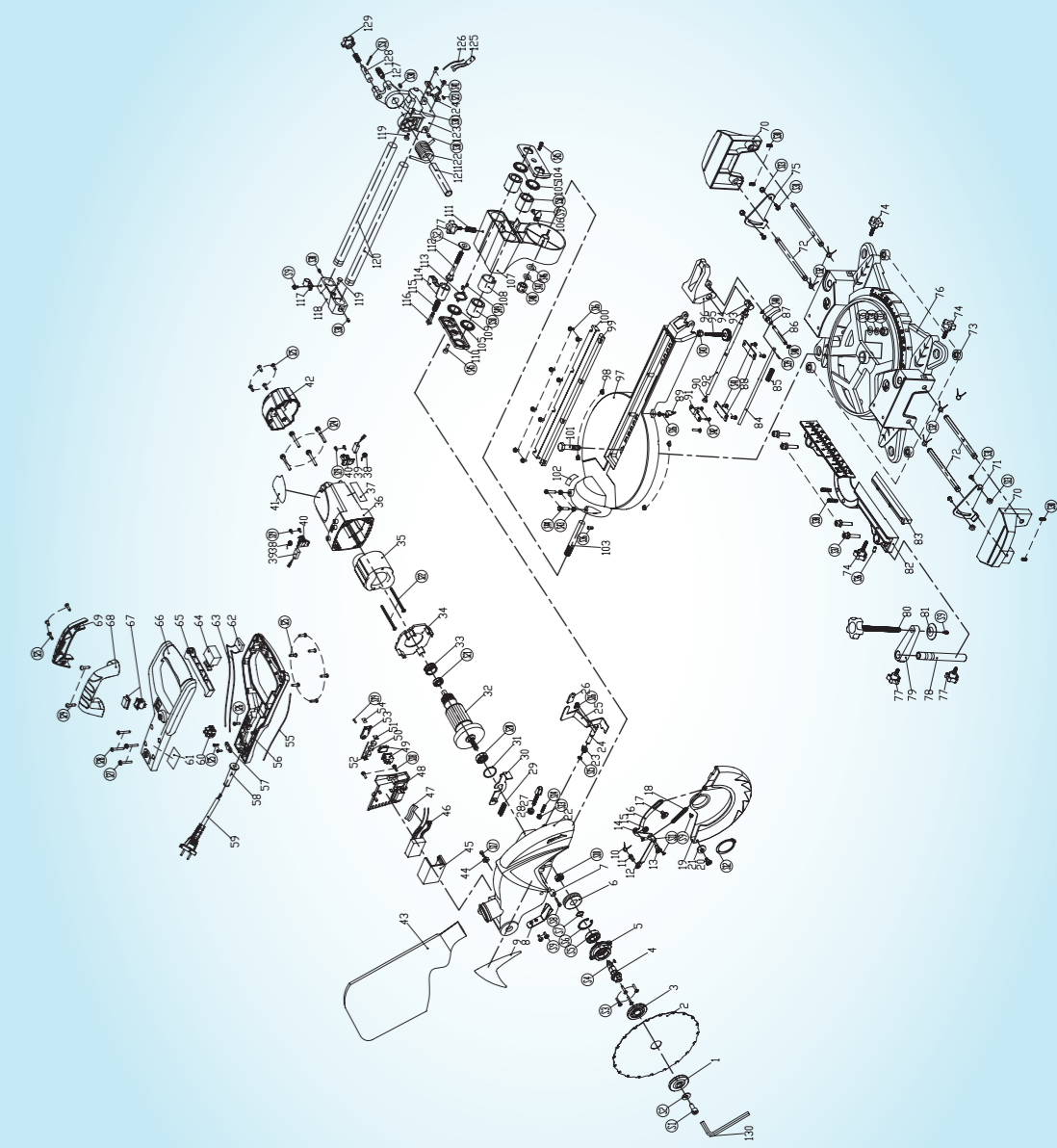

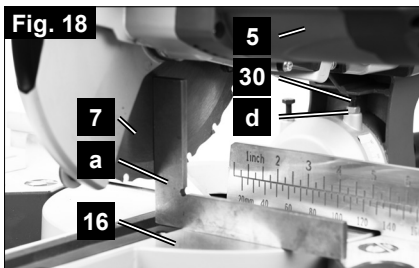
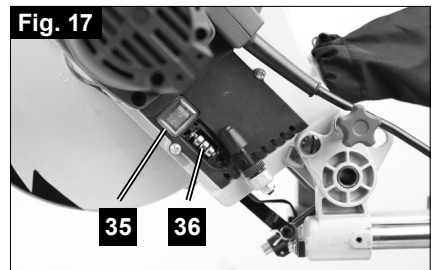
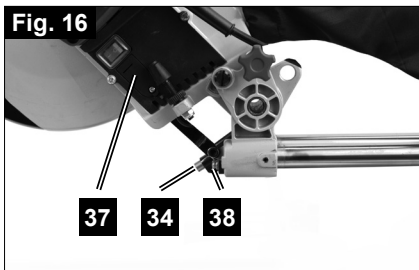
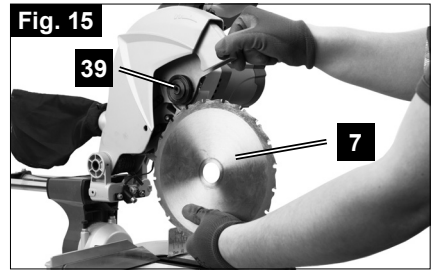
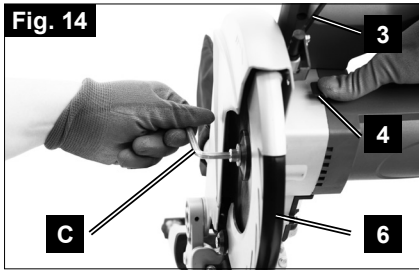
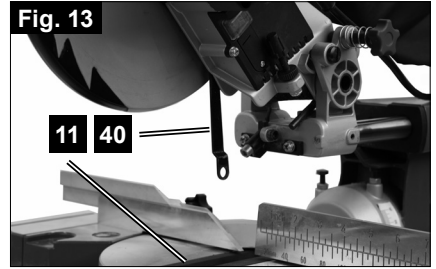
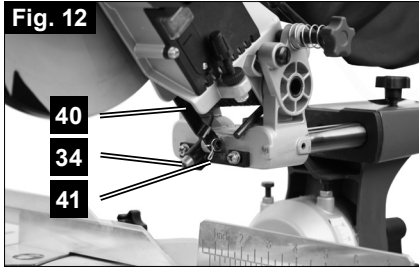

AFTER SALES SUPPORT

⚠ Attention!	These operating instructions provide places concerning your safety which are marked with this indication.
⚠ Caution!	Failure to follow these instructions may cause light to medium risk of injury
⚠ Warning!	Failure to follow these instructions may cause danger to life or danger of serious injuries!

Explanation of Symbols

	Caution - Read the operating instructions to reduce the risk of injury!
	Wear ear-muffs. The impact of noise can cause damage to hearing.
	Wear a breathing mask. Dust which is injurious to health can be generated when working on wood and other materials.
	Wear safety goggles. Sparks generated during working or splinters, chips and dust emitted by the device can cause loss of sight.
	Wear protection gloves during the saw blade change.
	Important! Risk of injury. Never reach into the running saw blade!
	Attention! Laser radiation Do not stare into the beam!
	Protection class II
	WARNING: Keep batteries out of reach of children. Swallowing may lead to serious injury or death in as little as 2 hours due to internal burns. If swallowed, go straight to a hospital emergency room. Dispose of used batteries immediately.
	Complies with the Australian standards.
	Warranty period of 60 months.

AFTER SALES SUPPORT

I. Introduction

Congratulations on choosing to buy a WORKZONE TITANIUM® product. All products brought to you by WORKZONE TITANIUM® are manufactured to the highest standards of performance and safety, and as part of our philosophy of customer service and satisfaction, are backed by our comprehensive 5 Year Warranty. We hope you will enjoy using your purchase for many years to come.

Note:

According to the applicable product liability law the manufacturer of this device is not liable for damages which arise on or in connection with this device in case of:

- improper handling,
- non-compliance with the instructions for use,
- repairs by third party, non-authorised skilled workers,
- installation and replacement of non-original spare parts,
- improper use,
- failures of the electrical system due to the non-compliance with the electrical specifications and regulations.

Recommendations:

Read the entire text of the operating instructions prior to the assembly and operation of the device.

These operating instructions are intended to make it easier for you to get familiar with your device and utilise its intended possibilities of use.

The operating instructions contain important notes on how to work safely, properly and economically with your machine and how to avoid dangers, save repair costs, reduce downtime, and increase the reliability and working life of the machine.

In addition to the safety regulations contained herein, you must in any case comply with the applicable regulations of your country with respect to the operation of the machine.

Put the operating instructions in a clear plastic folder to protect them from dirt and humidity, and store them near the machine. The instructions must be read and carefully observed by each operator prior to starting the work. Only persons who have been trained in the use of the machine and have been informed on the related dangers and risks are allowed to use the machine. The required minimum age must be met.

In addition to the safety notes contained in the present operating instructions and the special regulations of your country, the generally recognised technical rules for the operation of identically constructed machines must be observed.

II. Layout (Fig. 1-19)

1. Handle
2. ON/OFF switch
3. Release lever
4. Saw spindle lock
5. Machine head
6. Movable blade guard
7. Saw blade
8. Clamping device
9. Workpiece support
10. Locking screw for workpiece support
11. Table insert
12. Indexed position lever
13. Locking lever
14. Pointer
15. Scale
16. Turntable
17. Fixed saw table
18. Fence
19. Scale
20. Pointer
21. Sawdust bag
22. Set lever
23. Locking screw for drag guide
24. Fastening bolt
25. Drag guide
26. Screw for cutting depth limiter
27. Stop for cutting depth limiter
28. Movable fence
29. Set screw for moveable fence
30. Adjustment screw (90°)
31. Adjustment screw (45°)
32. Flange screw
33. Outer flange
34. Laser
35. ON/OFF switch for laser
36. Battery compartment
37. Battery compartment cover
38. Screw
39. Inner flange
40. Guide bar
41. Spring
42. Switch for switching speeds

AFTER SALES SUPPORT

11

- a) 90° angle gauge (not supplied)
- b) 45° angle gauge (not supplied)
- c) Allen key, 6 mm
- d) Counter nut for adjustment screw

III. Scope of delivery

1700W Sliding Mitre Saw
1 x Clamping device (8)
2 x Workpiece support (9)
1 x Dust bag (21)
1 x Allen key (c)
3 x LR44 Battery  (pre-installed)
1 x Operating manual

- Open the packaging and remove the device carefully.
- Remove the packaging material as well as the packaging and transport bracing (if available).
- Check that the delivery is complete.
- Check the device and accessory parts for transport damage.
- If possible, store the packaging until the warranty period has expired.

⚠ Attention!

The device and packaging materials are not toys!

Children must not be allowed to play with plastic bags, film and small parts!

There is a risk of swallowing and suffocation!

IV. Intended use

The trim, mitre and bevel saw is used to mitre wood, materials similar to wood, plastics and non-ferrous metals, with the exception of magnesium and alloys containing magnesium, according to the machine size.

Warning! The supplied saw blade is only intended for the sawing of wood! Do not use this blade for the sawing of plastic!

The equipment is to be used only for its prescribed purpose. Any other use is deemed to be a case of misuse. The user / operator and not the manufacturer will be liable for any damage or injuries of any kind caused as a result of this.

The equipment is to be operated only with suitable saw blades. It is prohibited to use any type of cutting-off or grinding wheel.

To use the equipment properly you must also observe the safety information, the assembly instructions and the operating instructions to be found in this manual.

All persons who use and service the equipment have to be acquainted with this manual and must be informed about the equipment's potential hazards. It is also

imperative to observe the accident prevention regulations in force in your area. The same applies for the general rules of health and safety at work.

The manufacturer will not be liable for any changes made to the equipment nor for any damage resulting from such changes. Even when the equipment is used as prescribed it is still impossible to eliminate certain residual risk factors. The following hazards may arise in connection with the machine's construction and design:

- Contact with the saw blade in the uncovered saw zone.
- Reaching into the running saw blade (cut injuries).
- Kick-back of workpieces and parts of workpieces.
- Saw blade fracturing.
- Catapulting of faulty carbide tips from the saw blade.
- Damage to hearing if ear-muffs are not used as necessary.
- Harmful emissions of wood dust when used in closed rooms.

Please note that our equipment has not been designed for use in commercial, trade or industrial applications. Our warranty will be voided if the equipment is used in commercial, trade or industrial businesses or for equivalent purposes.

V. Safety regulations

Attention! The following basic safety measures must be observed when using electric tools for protection against electric shock, and the risk of injury and fire. Read all these notices before using the electric tool and keep the safety instructions for later reference.

Safe work

- 1 Keep the work area orderly
 - Disorder in the work area can lead to accidents.
- 2 Take environmental influences into account
 - Do not expose electric tools to rain.
 - Do not use electric tools in a damp or wet environment.
 - Make sure that the work area is well-illuminated.
 - Do not use electric tools where there is a risk of fire or explosion.
- 3 Protect yourself from electric shock
 - Avoid physical contact with earthed parts (e.g. pipes, radiators, electric ranges, cooling units).
- 4 Keep children away
 - Do not allow other persons to touch the equipment or cable, keep them away from your work area.
- 5 Securely store unused electric tools
 - Unused electric tools should be stored in a dry, elevated or closed location out of the reach of children.

- 6 Do not overload your electric tool
 - They work better and more safely in the specified output range.
- 7 Use the correct electric tool
 - Do not use low-output electric tools for heavy work.
 - Do not use the electric tool for purposes for which it is not intended. For example, do not use handheld circular saws for the cutting of branches or logs.
 - Do not use the electric tool to cut firewood.
- 8 Wear suitable clothing
 - Do not wear wide clothing or jewellery, which can become entangled in moving parts.
 - When working outdoors, anti-slip footwear is recommended.
 - Tie long hair back in a hair net.
- 9 Use protective equipment
 - Wear protective goggles.
 - Wear a mask when carrying out dust-creating work.
- 10 Connect the dust extraction device if you will be processing wood, materials similar to wood, or plastics.
 - **ATTENTION!** The dust extractor must not be connected when processing metals. Risk of fire and explosion due to hot swarf or flying sparks! When processing metals, also remove the dust bag (21).
 - If connections for dust extraction and a collecting device are present, make sure that they are connected and used properly.
 - When processing wood, materials similar to wood, and plastics, operation in enclosed spaces is only permitted with the use of a suitable extraction system.
- 11 Do not use the cable for purposes for which it is not intended
 - Do not use the cable to pull the plug out of the outlet. Protect the cable from heat, oil and sharp edges.
- 12 Secure the workpiece
 - Use the clamping devices or a vice to hold the workpiece in place. In this manner, it is held more securely than with your hand.
 - An additional support is necessary for long workpieces (table, trestle, etc.) in order to prevent the machine from tipping over.
 - Always press the workpiece firmly against the working plate and stop in order to prevent bouncing and twisting of the workpiece.
- 13 Avoid abnormal posture
 - Make sure that you have secure footing and always maintain your balance.
 - Avoid awkward hand positions in which a sudden slip could cause one or both hands to come into contact with the saw blade.
- 14 Take care of your tools
 - Keep cutting tools sharp and clean in order to be able to work better and more safely.
 - Follow the instructions for lubrication and for tool replacement.

- Check the connection cable of the electric tool regularly and have it replaced by a recognised specialist when damaged.
 - Check extension cables regularly and replace them when damaged.
 - Keep the handle dry, clean and free of oil and grease.
- 15** Pull the plug out of the outlet
- Never remove loose splinters, chips or jammed wood pieces from the running saw blade.
 - During non-use of the electric tool or prior to maintenance and when replacing tools such as saw blades, bits, milling heads.
 - When the saw blade is blocked due to abnormal feed force during cutting, turn the machine off and disconnect it from power supply. Remove the work piece and ensure that the saw blade runs free. Turn the machine on and start new cutting operation with reduced feed force.
- 16** Do not leave a tool key inserted
- Before switching on, make sure that keys and adjusting tools are removed.
- 17** Avoid inadvertent starting
- Make sure that the switch is switched off when plugging the plug into an outlet.
- 18** Use extension cables for outdoors
- Only use approved and appropriately identified extension cables for use outdoors.
 - Only use cable reels in the unrolled state.
- 19** Remain attentive
- Pay attention to what you are doing. Remain sensible when working. Do not use the electric tool when you are distracted.
- 20** Check the electric tool for potential damage
- Protective devices and other parts must be carefully inspected to ensure that they are fault-free and function as intended prior to continued use of the electric tool.
 - Check whether the moving parts function faultlessly and do not jam or whether parts are damaged. All parts must be correctly mounted and all conditions must be fulfilled to ensure fault-free operation of the electric tool.
 - The moving protective hood may not be fixed in the open position.
 - Damaged protective devices and parts must be properly repaired or replaced by a recognised workshop, insofar as nothing different is specified in the operating manual.
 - Damaged switches must be replaced at a customer service workshop.
 - Do not use any faulty or damaged connection cables.
 - Do not use any electric tool on which the switch cannot be switched on and off.
- 21 ATTENTION!**
- Exercise elevated caution for double mitre cuts.
- 22 ATTENTION!**
- The use of other insertion tools and other accessories can entail a risk of injury.

- 23** Have your electric tool repaired by a qualified electrician
- This electric tool conforms to the applicable safety regulations. Repairs may only be performed by an electrician using original spare parts. Otherwise accidents can occur.
- 24** It is recommended that the tool always be supplied via a residual current device having a rated residual current of 30 mA or less.

ADDITIONAL SAFETY INSTRUCTIONS

1 Safety precautions

- **Warning!** Do not use damaged or deformed saw blades.
- Replace a worn table insert.
- Only use saw blades recommended by the manufacturer which conform to EN 847-1.
- Make sure that a suitable saw blade for the material to be cut is selected.
- Wear suitable personal protective equipment. This includes:
 - Hearing protection to avoid the risk of becoming hearing impaired,
 - Respiratory protection to avoid the risk of inhaling harmful dust,
 - Wear gloves when handling saw blades and rough materials. Carry saw blades in a container whenever practical.
 - Wear goggles. Sparks generated during work or splinters, chippings and dust coming from the device can lead to loss of eyesight.
- Connect a dust collecting device to the electric tool when sawing wood. The emission of dust is influenced, among other things, by the type of material to be processed, the significance of local separation (collection or source) and the correct setting of the hood/guide plates/guides.
- Do not use saw blades made of high-speed alloy steel (HSS steel).

2 Maintenance and repair

- Pull out the mains plug for any adjustment or repair tasks.
- The generation of noise is influenced by various factors, including the characteristics of saw blades, condition of saw blade and electric tool. Use saw blades which were designed for reduced noise development, insofar as possible. Maintain the electric tool and tool attachments regularly and if necessary, initiate repairs in order to reduce noise.
- Report faults on the electric tool, protective devices or the tool attachment to the person responsible for safety as soon as they are discovered.

3 Safe work

- Only use saw blades for which the maximum permissible speed is not lower than the maximum spindle speed of table saws and which are suitable for the material to be cut.
- Make sure that the saw blade does not touch the turntable in any position by pulling out the mains plug and rotating the saw blade by hand in the 45° and 90° position. If necessary, readjust the saw head.

- When transporting the electric tool, only use the transport devices. Never use the protective devices for handling or transport.
- Make sure that the lower part of the saw blade is covered during transport, e.g. by the protective device.
- Be sure to only use spacers and spindle rings specified by the manufacturer as suitable for the intended purpose.
- The floor around the machine must be level, clean and free of loose particles, such as chips and cutting residues.
- Do not remove any cutting residues or other parts of workpieces from the cutting zone while the machine is running and the saw unit is not at rest.
- Make sure that the machine is always secured on a workbench or a table if at all possible.
- Support long workpieces (e.g. with a roller table) to prevent them sagging at the end of a cut.

Warning! This electric tool generates an electromagnetic field during operation. This field can impair active or passive medical implants under certain conditions. In order to prevent the risk of serious or deadly injuries, we recommend that persons with medical implants consult with their physician and the manufacturer of the medical implant prior to operating the electric tool.

SAFETY INSTRUCTIONS FOR THE HANDLING OF SAW BLADES

- 1 Only use insertion tools if you have mastered their use.
- 2 Observe the maximum speed. The maximum speed specified on the insertion tool may not be exceeded. If specified, observe the speed range.
- 3 Observe the motor / saw blade direction of rotation.
- 4 Do not use any insertion tools with cracks. Replace cracked insertion tools. Repairs are not permitted.
- 5 Clean grease, oil and water off of the clamping surfaces.
- 6 Do not use any loose reducing rings or bushes for the reducing of holes on saw blades.
- 7 Make sure that fixed reducer rings for securing the insertion tool have the same diameter and have at least 1/3 of the cutting diameter.
- 8 Make sure that fixed reducer rings are parallel to each other.
- 9 Handle insertion tool with caution. They are ideally stored in the original package or special containers. Wear protective gloves in order to improve grip and to further reduce the risk of injury.
- 10 Prior to the use of insertion tools, make sure that all protective devices are properly fastened.
- 11 Prior to use, make sure that the insertion tool meets the technical requirements of this electric tool and is properly fastened.
- 12 Only use the supplied saw blade for sawing operations in wood.



Attention: Laser radiation
Do not stare into the beam
Class 2 laser



Protect yourself and you environment from accidents using suitable precautionary measures!

- Do not look directly into the laser beam with unprotected eyes.
- Never look into the path of the beam.
- Never point the laser beam towards reflecting surfaces and persons or animals. Even a laser beam with a low output can cause damage to the eyes.
- Caution - methods other than those specified here can result in dangerous radiation exposure.
- Never open the laser module. Unexpected exposure to the beam can occur.
- If the mitre saw is not used for an extended period of time, the batteries should be removed.
- The laser may not be replaced with a different type of laser.
- Repairs of the laser may only be carried out by the laser manufacturer or an authorised representative.

Safety instructions for handling batteries



DANGER if swallowed

- 1 Always make sure that the batteries are inserted with the correct polarity (+ and -), as indicated on the battery.
- 2 Do not short-circuit batteries.
- 3 Do not charge non-rechargeable batteries.
- 4 Do not overcharge batteries!
- 5 Do not mix old and new batteries or batteries of different types or manufacturers! Replace an entire set of batteries at the same time.
- 6 Immediately remove used batteries from the device and dispose of them properly!
- 7 Do not allow batteries to heat up!
- 8 Do not weld or solder directly on batteries!
- 9 Do not dismantle batteries!
- 10 Do not allow batteries to deform!
- 11 Do not throw batteries into fire!
- 12 Keep batteries out of the reach of children.
- 13 Do not allow children to replace batteries without supervision!
- 14 Do not keep batteries near fire, ovens or other sources of heat. Do not use batteries in direct sunlight or store them in vehicles in hot weather.

- 15 Keep unused batteries in the original packaging and keep them away from metal objects. Do not mix unpacked batteries or toss them together! This can lead to a short-circuit of the battery and thus damage, burns or even the risk of fire.
- 16 Remove batteries from the equipment when it will not be used for an extended period of time, unless it is for emergencies!
- 17 NEVER handle batteries that have leaked without appropriate protection. If the leaked fluid comes into contact with your skin, the skin in this area should be rinsed off under running water immediately. Always prevent the fluid from coming into contact with the eyes and mouth. In the event of contact, please seek immediate medical attention.
- 18 Clean the battery contacts and corresponding contacts in the device prior to inserting the batteries:

Residual risks

The machine has been built according to the state of the art and the recognised technical safety requirements. However, individual residual risks can arise during operation.

- Health hazard due to electrical power, with the use of improper electrical connection cables.
- Furthermore, despite all precautions having been met, some non-obvious residual risks may still remain.
- Residual risks can be minimised if the "safety instructions" and the "Proper use" are observed along with the whole of the operating instructions.
- Do not load the machine unnecessarily: excessive pressure when sawing will quickly damage the saw blade, which results in reduced output of the machine in the processing and in cut precision.
- When cutting plastic material, please always use clamps: the parts which should be cut must always be fixed between the clamps.
- Avoid accidental starting of the machine: the operating button may not be pressed when inserting the plug in an outlet.
- Use the tool that is recommended in this manual. In doing so, your mitre saw provides optimal performance.
- Hands may never enter the processing zone when the machine is in operation. Release the handle button and switch off the machine prior to any operations.

VI. Before starting the equipment

- The equipment must be set up where it can stand securely, i.e. it should be bolted to a workbench, a universal base frame or similar. To do this, use the holes located in the frame of the machine.
- All covers and safety devices have to be properly fitted before the equipment is switched on.
- It must be possible for the blade to run freely.

AFTER SALES SUPPORT

- When working with wood that has been processed before, watch out for foreign bodies such as nails or screws, etc.
- Before you press the ON/OFF switch check that the saw blade is fitted correctly. Moving parts must run smoothly.
- Before you connect the equipment to the power supply make sure the data on the rating plate are identical to the mains data.

VII. Assembling and operation

⚠ Warning! Prior to any adjustment work disconnect the mains power plug!

7.1 Assembling the saw (Fig. 1-6)

- To adjust the turntable (16), push the indexed position lever (12) downwards and pull the lower locking lever (13) upwards with your index finger.
- Rotate the turntable (16) and pointer (14) to the desired angle on the scale (15) and lock in place by folding up the the indexed position lever (12).
- Pressing the machine head (5) lightly downwards and removing the fastening bolt (24) from the motor bracket at the same time disengages the saw from the lowest position.
- Swing the machine head (5) up until the release lever (3) latches into place.
- It is possible to secure the clamping device (8) to the left or right on the fixed saw table (17). Long workpieces must be supported by the clamping device!
- Attach the workpiece supports (9) to the fixed saw table (17) as shown in Figure 6a,b,c and push them all the way through. Secure the shafts with the retaining springs to prevent them from slipping out accidentally. Then fasten them in the desired position with the screw (10).
- It is possible to tilt the machine head (5) a max. 45° to the left by loosening the set lever (22).

7.2 Sawdust bag (Fig. 2)

The saw is equipped with a sawdust bag (21) for sawdust and chips.

Squeeze together the metal ring on the dust bag and attach it to the outlet opening in the motor area.

The sawdust bag (21) can be emptied by means of a zipper at the bottom.

7.3 Using the laser (Fig. 16,17)

- **To switch on:** Move the ON/OFF switch of the laser (35) to the "I" position. A laser line is projected onto the material you wish to process, providing an exact guide for the cut.
- **To switch off:** Move the ON/OFF switch of the laser (35) to the "0" position.
- Replacing the battery: Switch off the laser (34). Remove the battery compartment cover (37). Remove the batteries and replace with new batteries (3 x LR44) Check that the battery terminals are positioned correctly when inserting new batteries. Close the battery compartment (36) again.

7.4 Changing the speed (Fig. 2)

The saw has 2 speed ranges:

- To operate the saw at a speed of 3800 rpm (non-ferrous metals), set the switch (42) to position I.
- To operate the saw at a speed of 5000 rpm (wood), set the switch (42) to position II.

7.5 Cross cut 90° and turntable 0° (Fig.1,2,6,7)

In the case of cutting widths up to approx. 100 mm it is possible to fix the traction function of the saw with the locking screw (23) in the rear position. In this position the machine can be operated in cross cutting mode. If the cutting width is over 100 mm then it is necessary to ensure that the locking screw (23) is loose and the machine head (5) can move.

Caution! For 90° mitre cuts, the moveable fence (28) must be fixed in the inner position.

- Open the set screw (29) on the moveable fence (28) and push the moveable fence (28) inwards.
- **Warning!** The moveable fence (28) must be locked in a position far enough from the inner position that the distance between the fence (28) and the saw blade (7) is no more than 5 mm.
- Before making the cut, check that no collision could occur between the fence (28) and the saw blade (7).
- Tighten the set screw (29) again.
- Move the machine head (5) to its upper position.
- Use the handle (1) to push back the machine head (5) and fix it in this position if required (dependent on the cutting width).
- Place the piece of wood to be cut at the fence (18) and on the turntable (16).
- Lock the material with the clamping device (8) on the fixed saw table (16) to prevent the material from moving during the cutting operation.
- Push down the release lever (3) to release the machine head (5).
- Press the ON/OFF switch (2) to start the motor.
- With the drag guide (23) fixed in place:
use the handle (1) to move the machine head (5) steadily and with light pressure downwards until the saw blade (7) has completely cut through the work piece.
- With the drag guide (23) not fixed in place:
pull the machine head (5) all the way to the front. Lower the handle (1) to the very bottom by applying steady and light downward pressure. Now push the machine head (5) slowly and steadily to the very back until the saw blade (7) has completely cut through the work piece.
- When the cutting operation is completed, release the on/off button first and raise the machine head once the blade has come to a complete stop.

Caution! The machine executes an upward stroke automatically due to the return spring, i.e. do not release the handle (1) after completing the cut; instead allow the machine head to move upwards slowly whilst applying light counter pressure.

7.6 Cross cut 90° and turntable 0° - 45° (Fig. 1,6,7)

The crosscut saw can be used to make crosscuts of 0° -45° to the left and 0° -45° to the right in relation to the fence.

Caution! For bevel cuts (inclined saw head), the moveable fence (28) must be fixed in the outer position.

- Open the set screw (29) on the moveable fence (28) and push the moveable fence (28) outwards.
- **Warning!** The moveable fence (28) must be locked in a position far enough from the inner position that the distance between the fence (28) and the saw blade (7) is no more than 5 mm.
- Before making the cut, check that no collision could occur between the fence (28) and the saw blade (7).
- Tighten the set screw (29) again.
- Use the locking lever (13) to adjust the turntable (16) to the desired angle. The pointer (14) on the turntable (16) must match the desired angle on the scale (15) on the fixed saw table (17).
- Tilt the locking lever (13) back up again to fix the turntable (16) in place.
- Cut as described under section 7.5.

7.7 Mitre cut 0°- 45° and turntable 0° (Fig. 1,2,6,8)

The crosscut saw can be used to make mitre cuts of 0° - 45° in relation to the work face.

Caution! To make mitre cuts (inclined saw head), the adjustable fence (28) must be fixed at the outer position.

- Open the set screw (29) for the adjustable fence (28) and push the adjustable fence outwards.
- **Warning!** The adjustable fence (28) must be fixed far enough in front of the innermost position that the distance between the fence (28) and the saw blade (7) amounts to a maximum of 5 mm.
- Before making a cut, check that the fence (28) and the saw blade (7) cannot collide.
- Secure the set screw (29) again.
- Move the machine head (5) to the top position.
- Fix the turntable (16) in the 0° position.
- Loosen the set lever (22) and use the handle (1) to angle the machine head (5) to the left, until the pointer (20) indicates the desired angle measurement on the scale (19).
- Re-tighten the set lever (22).
- Cut as described in section 7.5.

7.8 Mitre cut 0°- 45° and turntable 0°- 45° (Fig. 1,2,6,9)

The crosscut saw can be used to make mitre cuts to the left of 0°- 45° in relation to the work face and, at the same time, 0° - 45° to the left or 0° - 45° to the right in relation to the fence (double mitre cut).

Caution! To make mitre cuts (inclined saw head), the adjustable fence (28) must be fixed at the outer position.

- Open the set screw (29) for the adjustable fence (28) and push the adjustable fence outwards.
- **Warning!** The adjustable fence (28) must be fixed far enough in front of the innermost position that the distance between the fence (28) and the saw blade (7) amounts to a maximum of 5 mm.
- Before making a cut, check that the fence (28) and the saw blade (7) cannot collide.
- Secure the set screw (29) again.
- Move the machine head (5) to its upper position.
- Release the turntable (16) by loosening the screw (26).
- Using the Locking lever (13), set the turntable (16) to the desired angle (refer also to point 7.4 in this regard).
- Re-tighten the screw (26) in order to secure the turntable.
- Undo the set lever (22) and use the handle (1) to tilt the machine head (5) to the left until it coincides with the required angle value (in this connection see also section 7.6).
- Re-tighten the set lever (22).
- Cut as described under section 7.5.

7.9 Limiting the cutting depth (Fig. 3)

- The cutting depth can be continuously adjusted using the screw (26). To do this loosen the knurled nut on the screw (26). Turn the screw (26) in or out to set the required cutting depth. Then re-tighten the knurled nut on the screw (26).
- Check the setting by completing a test cut. Cutting capacity: See VIII Technical data

7.10 Precision adjustment for crosscut 90° (Fig. 3,5,18)

- **No angle gauge included.**
- Lower the machine head (5) and secure using the locking bolt (24).
- Loosen the set lever (22).
- Position the angle gauge (a) between the saw blade (7) and the turntable (16).
- Slacken the counternut (d). Adjust the adjusting screw (30) until the angle between the saw blade (7) and turntable (16) is 90°.
- Retighten the counternut (d) to secure this setting.
- Subsequently check the position of the angle indicator. If necessary loosen the pointer (20) using a Philips screwdriver, set to position 0° on the angle scale (19) and re-tighten the retaining screw.

7.11 Precision adjustment for mitre cut 45° (Fig. 1,3,5,19)

- **No angle gauge included.**

- Lower the machine head (5) and secure using the fastening bolt (24).
- Fix the turntable (16) in the 0° position.
- Loosen the set lever (22) and use the handle (1) to angle the machine head (5) 45° to the left.
- 45° - position angle gauge (b) between the saw blade (7) and turntable (16).
- Slacken the counternut (c). Adjust the adjusting screw (31) until the angle between the saw blade (7) and turntable (16) is precisely 45°.
- Retighten the counternut (d) to secure this setting.

7.12 Changing the saw blade (Fig. 11-15)

Remove the power plug!

⚠ Caution!

Wear safety gloves when changing the saw blade. Risk of injury!

- Remove the spring (41) from the pin by pushing together the two ends.
- Release the guide bar (40) from the pin.
- Firmly press the saw spindle lock (4), and slowly turn the flange screw (32) clockwise. After max. one turn, the saw spindle lock (4) engages.
- Then undo the flange screw (32), by applying a slightly greater force in a clockwise direction.
- Fully unscrew the flange screw (32) and remove the outer flange (33).
- Press the release lever (3) to slide back the movable blade guard (6), then remove the saw blade (7) from the inner flange (39) and pull out in a downwards direction. Do not use the saw without guards in position and additional safety instruction, if double bevel-cutting is possible.
- Carefully clean the flange screw (32), outer flange (33) and inner flange (39).
- Insert the new saw blade (7) in the reverse sequence and tighten.
- Position the guide bar (40) on the pin again, and secure with the spring (41).
- **Warning!** The cutting angle of the teeth, in other words the direction of rotation of the saw blade (7) must coincide with the direction of the arrow on the housing.
- Before continuing your work make sure that all safety devices are in good working condition.
- **Warning!** Every time that you change the saw blade (7), check to see that it spins freely in the table insert (11) in both perpendicular and 45° angle settings.
- **Warning!** The work to change and align the saw blade (7) must be carried out correctly.

VIII. Technical data

AC motor	230 - 240 V~ 50Hz
Power	1700 Watt
Operating mode	S6 20% 5 Min*
Idle speed n_0	3800 / 5000 min ⁻¹
Carbide saw blade	∅ 216 x ∅ 30 x 2,8 mm
Number of teeth	40
Mitre cut	-47° / 0° / +47°
Swivel range	0° - 45° to left
Cross cut at 90°	305 x 65 mm
Mitre cut at 45°	215 x 65 mm
Bevel cut at 45°	305 x 36 mm
Saw width at 2 x 45° (double mitre cut)	215 x 36 mm
Protection class	II
Weight	12,2 kg
Laser class	2
Wavelength of laser	650 nm
Laser output	≤ 1 mW
Laser module power supply	3 x LR44 button cell

* S6, continuous operation periodic duty.

Identical duty cycles with a period at load followed by a period at no load.
Running time 5 minutes; duty cycle is 20% of the running time.

The work piece must have a minimum height of 3mm and a minimum width of 10 mm.

Make sure that the workpiece is always secured with the clamping device.

Noise and vibration

Total vibration values determined in accordance with EN 61029-1.

sound pressure level L_{PA}	95 dB(A)
uncertainty K_{PA}	3 dB
sound power level L_{WA}	108 dB(A)
uncertainty K_{WA}	3 dB

AFTER SALES SUPPORT

25

  1300 855 831

 support@schepach.com.au

MODEL:HM80MP PRODUCT CODE: 53666 06/2019

Wear hearing protection.

The effects of noise can cause a loss of hearing. Total vibration values (vector sum - three directions) determined in accordance with EN 61029.

IX. Transport (Fig. 1,2)

- Tighten the screw (26) in order to lock the turntable (16)
- Activate the release lever (3), press the machine head (5) downwards and secure with the fastening bolt (24). The saw is now locked in its bottom position.
- Fix the saw's drag function with the locking screw for drag guide (23) in rear position.
- Carry the equipment by the fixed saw table (17).
- When reassembling the equipment proceed as described under section 7.1.

X. Maintenance

⚠ Warning! Prior to any adjustment, maintenance or service work disconnect the mains power plug!

General maintenance measures

Wipe chips and dust off the machine from time to time using a cloth. In order to extend the service life of the tool, oil the rotary parts once monthly. Do not oil the motor. When cleaning the plastic do not use corrosive products.

Brush inspection

Check the carbon brushes (located behind the motor cover) after the first 50 operating hours with a new machine, or when new brushes have been fitted.

After carrying out the first check, repeat the check every 10 operating hours.

If the carbon is worn to a length of 6 mm, or if the spring or contact wire are burned or damaged, it is necessary to replace both brushes. If the brushes are found to be usable following removal, it is possible to reinstall them.

The replacement of the carbon brushes can only be conducted by an expert.

XI. Storage

Store the device and its accessories in a dark, dry and frost-proof place that is inaccessible to children. The optimum storage temperature is between 5 and 30°C.

Store the electrical tool in its original packaging.

Cover the electrical tool in order to protect it from dust and moisture.

Store the operating manual with the electrical tool.

XII. Electrical connection

The electrical motor installed is connected and ready for operation. The connection complies with the applicable Australian standards.

The customer's mains connection as well as the extension cable used must also comply with these regulations.

Important information

In the event of an overloading the motor will switch itself off. After a cool-down period (time varies) the motor can be switched back on again.

Damaged electrical connection cable

The insulation on electrical connection cables is often damaged.

This may have the following causes:

- Passage points, where connection cables are passed through windows or doors.
- Kinks where the connection cable has been improperly fastened or routed.
- Places where the connection cables have been cut due to being driven over.
- Insulation damage due to being ripped out of the wall outlet.
- Cracks due to the insulation ageing.

Such damaged electrical connection cables must not be used and are life-threatening due to the insulation damage. Check the electrical connection cables for damage regularly. Make sure that the power is switched off before inspecting the cable. Electrical connection cables must comply with the applicable Australian standards and must be correctly marked. Only use connection cables with the marking "H05VV-F". Replacement cables can only be fitted by an approved and certified electrician. If you are in any doubt please contact the help line at the foot of this page.

AC motor

- The mains voltage must be 230 - 240 V~
- Extension cables up to 25 m long must have a cross-section of 1.5 mm².

Connections and repairs of electrical equipment may only be carried out by an electrician.

Please provide the following information in the event of any enquiries:

- Type of current for the motor
- Machine data - type plate
- Machine data - type plate

XIII. Disposal and recycling

The equipment is supplied in packaging to prevent it from being damaged in transit. The raw materials in this packaging can be reused or recycled. The equipment and its accessories are made of various types of material, such as metal and plastic. Defective components must be disposed of as special waste. Ask your dealer or your local council.

XIV. Troubleshooting

Fault	Possible cause	Remedy
Motor does not work	Motor, cable or plug defective, fuses burnt	Arrange for inspection of the machine by a specialist. Never repair the motor yourself. Danger! Check fuses and replace as necessary
The motor starts up slowly and does not reach operating speed.	Voltage too low, coils damaged, capacitor burnt	Contact the utility provider to check the voltage. Arrange for inspection of the motor by a specialist. Arrange for replacement of the capacitor by a specialist
Motor makes excessive noise	Coils damaged, motor defective	Arrange for inspection of the motor by a specialist
The motor does not reach its full power.	Circuits in the network are overloaded (lamps, other motors, etc.)	Do not use any other equipment or motors on the same circuit
Motor overheats easily.	Overloading of the motor, insufficient cooling of the motor	Avoid overloading the motor while cutting, remove dust from the motor in order to ensure optimal cooling of the motor
Reduced cutting power when sawing	Saw blade too small (ground too much)	Readjust end stop of the saw unit
Saw cut is rough or wavy	Saw blade dull, tooth shape not appropriate for the material thickness	Resharpen saw blade and/or use suitable saw blade
Workpiece pulls away and/or splinters	Excessive cutting pressure and/or saw blade not suitable for use	Insert suitable saw blade



1700W SLIDING MITRE SAW

Warranty Details

REGISTER YOUR PURCHASE AT www.aldi.com.au/en/about-aldi/product-registration/ TO KEEP UP-TO-DATE WITH IMPORTANT PRODUCT INFORM

The product is guaranteed to be free from defects in workmanship and parts for a period of 60 months from the date of purchase. Defects that occur within this warranty period, under normal use and care, will be repaired, replaced or refunded at our discretion.

The benefits conferred by this warranty are in addition to all rights and remedies in respect of the product that the consumer has under the Competition and Consumer Act 2010 and similar state and territory laws.

Our goods come with guarantees that cannot be excluded under the Australian Consumer Law. You are entitled to a replacement or refund for a major failure and for compensation for any other reasonably foreseeable loss or damage. You are also entitled to have the goods repaired or replaced if the goods fail to be of acceptable quality and the failure does not amount to a major failure.

AFTER SALES SUPPORT

29

  1300 855 831

 support@schepach.com.au

MODEL:HM80MP PRODUCT CODE: 53666 06/2019

**ALDI****WORKZONE[®]**
TITANIUM+**1700W SLIDING MITRE SAW**

Repair and Refurbished Goods or Parts Notice

Unfortunately, from time to time, faulty products are manufactured which need to be returned to the Supplier for repair.

Please be aware that if your product is capable of retaining user-generated data (such as files stored on a computer hard drive, telephone numbers stored on a mobile telephone, songs stored on a portable media player, games saved on a games console or files stored on a USB memory stick) during the process of repair, some or all of your stored data may be lost.

We recommend you save this data elsewhere prior to sending the product for repair.

You should also be aware that rather than repairing goods, we may replace them with refurbished goods of the same type or use refurbished parts in the repair process.

Please be assured though, refurbished parts or replacements are only used where they meet ALDI's stringent quality specifications.

If at any time you feel your repair is being handled unsatisfactorily, you may escalate your complaint. Please telephone us on 1300 855 831 or write to us at:

RossMac Pty. Ltd.

P.O. Box 261, Essendon North, Victoria, 3041

1300 855 831

support@scheppach.com.au