



# User Manual

## Contents



### GARDEN LAWN EDGER LE3200P

AUS



Original instructions  
Vers.No. 190611

- Overview .....04
- Utilisation .....05
- Explanation of symbols .....08
- Introduction .....09
- Layout .....10
- Scope of delivery .....11
- Intended use .....12
- Safety information .....13
- Before starting .....17
- Operation .....18
- Maintenance, cleaning and servicing .....20
- Technical data .....22
- Storage.....23
- Transport .....24
- Disposal and recycling .....24
- Troubleshooting .....25
- Warranty Details .....27
- Repair and Refurbished Goods or Parts Notice .....29

ALDI guarantees that our exclusive brand products are developed to our stringent quality specifications. If you are not entirely satisfied with this product, please return it to your nearest ALDI store within 60 days from the date of purchase for a full refund or replacement, or take advantage of our after sales support by calling the supplier's Customer Service Hotline.







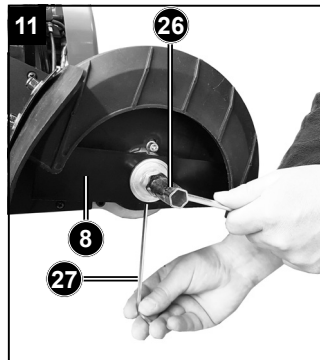
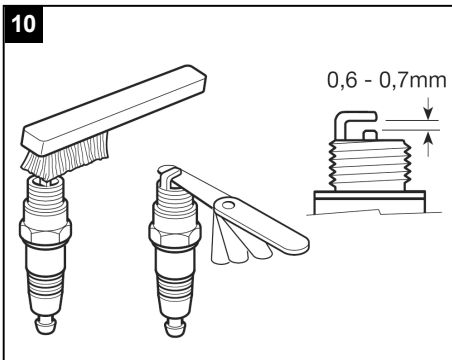
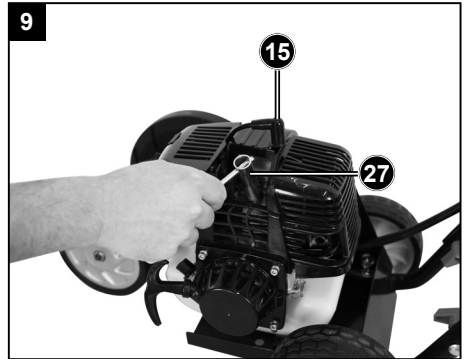
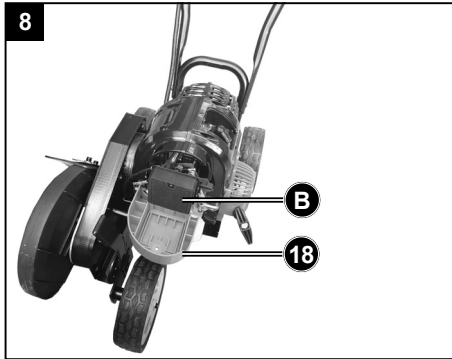





**Made in China**  
FERREX is a registered trademark of ALDI Stores  
DISTRIBUTED BY:  
ALDI STORES  
1 SARGENTS ROAD  
MINCHINBURY NSW 2770  
www.aldi.com.au

**AFTER SALES SUPPORT**   
☎ AUS 1300 855 831    ✉ support@scheppach.com.au  
MODEL: LE3200P PRODUCT CODE: 10102    08/2019

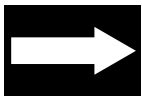
**3**  
YEAR WARRANTY

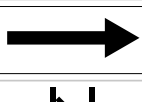

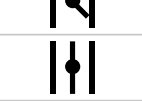
## EXPLANATION OF SYMBOLS

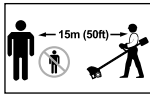
	Machine complies with the Australian standards and regulations.		Warning! Beware of thrown objects hit by cutting attachments.
	Read the complete user manual before using the appliance.		Warning! Risk of injury! Do not let your feet come in contact with the blades when the motor is running.
	Wear safety goggles!		Rotation direction of cutting blade.
	Use hearing protection!		Position of cutting blade.
	Warning! Petrol is very flammable. Avoid smoking or bringing any flame or sparks near petrol.		Choke lever 'cold start'
	Protect the machine from getting wet!		Choke lever 'warm start and work'
	Pay attention! Hot surfaces.		
	Warning! Keep all children, bystanders and helpers 15 meters away from the tool!		

## I. INTRODUCTION

Congratulations on choosing to buy a FERREX® product.

All products brought to you by FERREX® are manufactured to the highest standards of performance and safety, and as part of our philosophy of customer service and satisfaction, are backed by our comprehensive 3 Year Warranty.

We hope you will enjoy using your purchase for many years to come.

### **Note:**

According to the applicable product liability law the manufacturer of this device is not liable for damages which arise on or in connection with this device in case of:

- improper handling,
- non-compliance with the instructions for use,
- repairs by third party, non-authorised skilled workers,
- installation and replacement of non-original spare parts,
- improper use.

### **Recommendations:**

Read the entire text of the operating instructions prior to the assembly and operation of the device.

These operating instructions are intended to make it easier for you to get familiar with your device and utilise its intended possibilities of use.

The operating instructions contain important notes on how to work safely, properly and economically with your machine and how to avoid dangers, save repair costs, reduce downtime, and increase the reliability and working life of the machine.

In addition to the safety regulations contained herein, you must in any case comply with the applicable regulations of your country with respect to the operation of the machine.

Keep the operating instructions in a clear plastic folder to protect them from dirt and humidity, store them near the machine. The instructions should be read and carefully understood by each operator prior to using the machine. Only persons who have been trained in the use of the machine and are aware of the related dangers and risks should be allowed use the machine. The local required minimum age must be met.

In addition to the safety notes contained in these operating instructions and any specific regulations in your country, the generally recognised technical rules for the operation of identically constructed machines must be observed.

---

## AFTER SALES SUPPORT

## II. LAYOUT (Fig. 1 / 2)

- 1 On/Off switch
- 2 Throttle lever
- 3 Upper handle
- 4 Mid handle
- 5 Lower handle
- 6 Wheel
- 7 Rubber protection
- 8 Cutting blade
- 9 Blade guard
- 10 Fuel tank cap
- 11 Oil tank cap
- 12 Fuel tank
- 13 Recoil starter
- 14 Cover
- 15 Spark plug cover
- 16 Choke lever
- 17 Primer bulb
- 18 Air filter cover
- 19 Height adjustment lever
- 20 Mounting plate
- 21 Handle lock knob
- 22 Screw
- 23 Disc
- 24 Nut
- 25 Open end wrench
- 26 Spark plug wrench
- 27 Allen key

### III. SCOPE OF DELIVERY

Lawn edger	(1x)
Upper handle	(1x)
Mid handle	(1x)
Rubber protection	(1x)
Mounting plate	(1x)
Handle lock knob	(4x)
Screw	(4x)
Disc	(2x)
Nut	(2x)
Open end wrench	(1x)
Allen key	(1x)
Spark plug wrench	(1x)
Warranty Card	(1x)
Instruction manual	(1x)

- Open the packaging and take out the machine with care.
- Remove the packaging material.
- Check that all listed contents are present.
- Inspect the equipment and parts for any damage. Please contact the helpline if anything is missing.
- If possible, keep the packaging until the end of the guarantee period.
- Read the operating instructions fully to familiarise yourself with the tool prior to using it.
- Only use original accessories and spare parts. Spare parts are available by contacting the helpline.
- Specify the part numbers when you contact the helpline.

#### **⚠ ATTENTION!**

**The device and packaging materials are not toys!**

**Children must not be allowed to play with plastic bags, film and small parts!**

**There is a risk of swallowing and suffocation!**

## IV. INTENDED USE

The lawn edger is designed to look after domestic areas of grass and lawn. Due to the physical danger to the user and other persons, the appliance may not be used for other purposes.

The machine has been designed to be operated by one person.

The machine must not be used for cutting bushes, hedges and thickets, for cutting and mulching creepers or lawns on roofs or in balcony boxes. The machine must also not be used as a crusher for mulching tree cuttings and hedges or levelling any terrain roughness. Use the appliance only outside, never use it in confined and bad ventilated areas.

The machine is to be used only for its prescribed purpose. Any other use is deemed to be a case of misuse. The user / operator and not the manufacturer will be liable for any damage or injuries of any kind caused as a result of this.

Please note that our machine has not been designed for use in commercial, trade or industrial applications. Our warranty will be voided if the machine is used in commercial, trade or industrial businesses or for equivalent purposes.

The operating instructions as supplied by the manufacturer must be followed at all times to ensure that the machine is used properly. Any use which is not expressly permitted in the manual may result in damage to the equipment and place the user in serious danger. Observe the restrictions in the safety instructions.

### **Non-permitted users:**

Persons who are not familiar with the operating manual, children, young people under the age of 18 as well as persons under the influence of alcohol, drugs or medication shall not be permitted to operate the unit.

**WARNING! For your own safety, please thoroughly read this manual and the general safety instructions before turning the machine on. If you give the device to third parties, always include these instructions.**

## V. SAFETY INFORMATION

### Working Safely

Before starting this device, read and keep to the following advice. Also observe the safety provisions applicable in the respective country, in order to protect yourself and others from possible injury.

Repair works on the device must be carried out by the manufacturer or by companies appointed by the manufacturer respectively.

### Primary users

Persons working for the first time with the machine must obtain a practical instruction to the use of the machine and the operator protection equipment by an experienced operating person.

- Be attentive. Be careful what you do. Behave sensibly when working. Do not use the machine when you are tired or under the influence of drugs, alcohol or medication. One moment of carelessness when using the device can result in serious injuries.
- Make yourself familiar with the machine before using it, by reading and understanding the operating instructions. Insufficiently informed operators may put at risk their own and the health of other persons.
- Do not use the machine for unsuitable purposes (see 'Intended use').
- Avoid abnormal posture. Provide a safe standing position and keep your balance at all times.
- Wear suitable work clothes:
  - Do not wear loose-fitting clothes or jewellery; they can catch in moving parts.
  - Gloves and slip-proof shoes
  - Hairnet in case of long hair
- Wear protective clothing:
  - ear protection
  - protective goggles or face protection
  - protective gloves
  - safety boots
  - certificated hardhat in situations where injuries to the head might be expected.
- We recommend to wear leg protection and a safety jacket.
- Keep your workplace in an orderly condition! Untidiness can result in accidents.
- Take into consideration environmental influences:
  - Do not expose the machine to rain.

---

## AFTER SALES SUPPORT



- Do not use the machine in a damp or wet environment.
- Delay the work in case of disadvantageous weather (rain, snow, ice, wind) – increased risk of accidents!
- Provide for good illumination.
- Do not use the machine near inflammable liquids or gases.
- Familiarize yourself with your environment and pay attention to possible dangers such as wires and power lines. Remember, you may not be able to hear because of the motor noise.
- Never leave the machine unattended.
- For breaks the machine has to be put down in such a manner that no person will be endangered. Assure the machine against unauthorised access.
- Persons under the age of 18 must not operate the device.
- Keep other persons away.
- The operator is responsible for accidents or risks which occur to other persons or their properties.
- The operator is responsible to third persons within the area of operations.
- Keep children away.
- Do not allow other persons, especially children, to touch the machine. Keep them away from your working area.
- Do not use a blunt, broken or otherwise damaged cutting device.
- Be sure that the cutting device is moving before you start cutting.
- Do not overload the machine! You work better and safer in the given performance range.
- Only operate the machine with complete and correctly attached safety equipment and do not alter anything on the machine that could impair the safety.
- Do not modify the device or parts of the device respectively.
- Do not use any blades which do not comply with the indicated characteristics of this instruction manual.

### Safe handling of fuels

Fuels and fuel vapours are flammable and may cause serious injury on the skin or when inhaled. Therefore be careful and provide sufficient ventilation when handling with fuels.

- Stop the engine and allow the device to cool down before fuelling it.
- Do not smoke and avoid open flames when fuelling.
- Wear gloves when fuelling.
- Never refuel or drain the tank indoors.
- Avoid spilling of fuel or oil. Clean the machine immediately when you have spilled

fuel or oil. Change your clothes immediately when you have spilled fuel or oil on them.

- Make sure that no fuel can come into the soil.
- Carefully close the tank cap after fuelling and check that it does not get loose during operation.
- Check that there is no leakage on the tank cap and fuel lines. If there are leaks this device may not be started. Go away at least three metres from the fuelling place to start the device.
- Only transport and store fuels in containers approved and identified for this.
- Keep children away from fuels.
- Never store the machine or fuel container inside where there is an open flame, such as near a water heater.
- To reduce the fire risk keep the motor and silencer free from cutting remainders, leaves and lubricants.

### **Additional safety instructions for petrol edgers**

Even when the machine is used as prescribed it is not possible to eliminate all residual risk factors. The following hazards may arise in connection with the machines construction and design:

- Contact with the blade.
- Kickback of the machine due to hidden solid objects.
- Blade fracture.
- Catapulting of blade pieces.
- Damage to hearing if effective earmuffs are not worn.
- Do not use blades that are deformed or cracked.
- Do not operate in a hazardous location. Such areas include where there is a risk of explosion of petrol fumes, leaking gas or explosive dust.
- Do not operate in a confined area. Exhaust gases, smoke or fumes could reach dangerous concentrations.
- Protect your machine. This machine is NOT WEATHERPROOF and should not be exposed to direct sunlight, high ambient temperature and damp, wet or high humidity conditions.
- Do not smoke while refuelling. This is potentially dangerous as it may ignite the fuel and cause an explosion.
- Take care not to spill fuel. When refuelling the machine ensure that the motor has been switched off. Prevent the spilling of fuel as this may also ignite with the hot motor. Never refuel whilst the engine running.
- Be careful where you store the machine. Store the machine in a dry area away

from flammable liquids.

- Keep your distance. The machine emits exhaust fumes. Ensure bystanders keep a safe distance.
- Never fill fuel tank indoors. Never fill fuel tank when engine is running or hot. Do not smoke when filling fuel tank.
- When making any adjustments to the machine always wait for the blade to come to a complete stop and turn off the machine.
- Never attempt to unclog the blade chamber by tapping the machine on the ground, this can damage the unit.
- Keep hands clear of edge guide and blade when cleaning as these wear to a very sharp point during edging.
- Before landscaping or trenching, inspect and ensure there are no exposed or buried cables or pipes or other objects that may create a hazard or interfere with operating the machine.
- Set depth to only that required for the job, do not overload. If tool slows, pull back slightly and wait until blade returns to normal speed.
- Check damaged parts before further use of the machine, a guard or other part that is damaged should be carefully checked to determine that it will operate properly and perform it's intended function. Check for alignment of moving parts, binding of moving parts, mounting, and any other conditions that may affect it's operation.
- Ensure guards are kept in place.
- Always keep blade area clean.
- When using the machine, stones, pieces of metal and other objects can be thrown out at high speed by the blade. The tool and guard are designed to reduce the danger. However, the following special precautions should be taken:
  - Make sure that other people and pets are at least 5 metres away.
  - Always stand to left side of main handle.
  - Before landscaping or trenching, check for buried electrical cables.
  - To reduce the risk of injury, work going away from nearby solid objects such as walls, steps, stones, trees etc. Use great care when working close to solid objects, and where necessary, do edging or trimming by hand.
- Use only blades as recommended.
- Do not attempt to free a jammed blade before first switching off the machine.
- Let the blade come to rest naturally.
- Periodically check that all fixings are properly tightened.

**In addition, in spite of all the precautionary measures taken, non-obvious residual risks can still exist.**

**Store all safety notices and instructions for the future.**

## VI. BEFORE STARTING

### Mounting of the handles (Fig. 3)

- Place the mid handle (4) onto the lower handle (5). Ensure that the holes in the bars of both handle frames are in alignment. Using two of the handle lock knob (21) and screws (22), fix both handle frames together. The handle lock knobs (21) should be positioned on the inside of the frame. Tighten them securely.
- Attach the upper handle (3) to the mid handle (4) with the remaining two handle lock knobs (21) and screws (22) .
- Attach the cable container with the clip (A) at the upper handle (3).

### Mounting of the rubber protection (Fig. 4 / 5)

- Place the rubber protection (7) at the screws of the blade guard (9).
- Mount the mounting plate (20) at the screws of the blade guard (9) with the disc (23) and nut (24).
- Use the open end wrench (25) to tighten the nuts (24).

### Filling the engine oil (Fig. 1)

**⚠ WARNING!** Engine oil has been drained for shipping. Failure to fill engine sump with oil before starting the engine may result in permanent damage and will void warranty.

- Remove the oil tank cap (11).
- Fill in 100 ml of SAE 10W-30 engine oil (not included).
- Install and secure the oil tank cap (11) again.

### Checking the oil level (Fig. 1 / 6)

**⚠ WARNING!** Please check the engine oil level before each use, otherwise there is a risk that the engine can be damaged.

- Remove the oil tank cap (11).
- Clean the oil tank cap (11) with a cloth or rag.
- Re-insert the oil tank cap (11) momentarily. Remove and look at the oil tank cap (11) to determine oil level.
- The engine oil level must be between the two marking lines at the oil tank cap (11).
- Refill the engine oil if necessary.

**Filling the fuel (Fig. 1)**

⚠ **WARNING!** Fuel has been drained for shipping. Failure to fill fuel tank (12) with petrol before starting the engine may result in permanent damage and will void warranty.

⚠ **WARNING!** Do not overfill the fuel tank (12).

⚠ **WARNING!** Do not smoke while re-fueling.

**DO NOT USE FUEL WITH ETHANOL MIXTURE.**

- Use unleaded petrol with a minimum of Octane 91.
- Use clean, fresh fuel; purchase fuel in quantities that can be used every 30 days, to prevent gum or foaming inside the container and/or fuel tank (12).
- Remove the fuel tank cap (10).
- Fill with 0.7l petrol.
- Install and secure the fuel tank cap (10) again.

**VII. OPERATION**

⚠ **WARNING!** You may not start to operate the machine until you have read these operating instructions, observed all the instructions given and completely and properly assembled the machine!

**Adjusting the cutting depth (Fig. 7)**

The machine has a height adjustment lever (19) with five different height settings to easily adjust the cutting height.

- To decrease the cutting height pull the height adjustment lever (19) out and move it up a notch, towards the handlebar.
- To increase the cutting height pull the height adjustment lever (19) out and move it down a notch, towards the front of the unit.

**NOTE:** If you are unsure of which cutting height to use, begin with a high setting and complete a trial cut on a small section of the lawns edge. Readjust if necessary.

## Starting and stopping (Fig. 1)

### Starting

**NOTE:** Do not squeeze the throttle lever (2) before starting.

1. Press the On/Off switch (1) on the handle to the On (I) position.
2. Press the primer bulb (17) 5 times.
3. Push the choke lever (16) up to the start position .

**NOTE:** Pressing the primer bulb (17) and setting the choke lever (16) to the start position is unnecessary if the engine is warm or you work with the machine in warm conditions.

4. Pull the recoil starter (13), till the engine starts.
5. Once the engine has started, move the choke lever (16) to  position. Allow the engine to warm up for 2 minutes.
6. Tilt the machine backwards at the upper handle (3), so that the cutting blade (8) is clear of the ground.
7. Squeeze the throttle lever (2) to move the cutting blade (8).

### Stopping

1. Release the throttle lever (2) so that the engine is idling and the cutting blade (8) stops spinning.
2. Press the On/Off switch (1) on the handle to the Off (0) position.

### Edging (Fig. 1)

**⚠ WARNING!** Before edging, check that the area is clear of any obstacles and objects that could be thrown.

**NOTE:** If the cutting depth needs adjusting, this should be done progressively until the desired depth is reached. Do not overload, keep initial cutting depth at minimum. If the edger slows, pull back slightly and wait until the cutting blade (8) returns to normal speed.

1. While the engine is idling, line up the lawn edger cutting blade (8) with the edge to be cut. Use the arrow label on the blade guard (9) to assist in guiding you where the cutting blade will cut.
2. Before beginning to edge, tilt the upper handle (3) down so the cutting blade (8) is above ground level. This assists in the prevention of kickback.
3. When starting to edge, pull the throttle lever (2). Run the engine at full throttle and lower the cutting blade (8) gently into the ground. Be careful not to hit concrete

---

## AFTER SALES SUPPORT

with the blade.

4. Walk forward slowly, keeping the cutting blade (8) aligned with the edge to be cut. If the lawn edger begins to slow down due to a build up of grass in the blade guard (9), walk back slightly to allow the grass to fall out. Let the cutting blade (8) return to normal speed before continuing forward.

**NOTE:** Some sparks may be generated from the cutting blade (8) while pressed against a solid edge (eg; concrete) to be cut, simply align the cutting blade (8) so no contact is made.

**NOTE:** If the blade guard (9) becomes clogged, tilt the upper handle (3) so the cutting blade (8) is above ground level. This assists in clearing the debris from the cutting blade (8) and blade guard (9). If the debris does not fall out, stop the motor, wait for the cutting blade (8) to stop rotating and remove debris from the blade guard (9).

**⚠ WARNING!** The motor housing may become very hot during use. Avoid contact during and after operation.

## VIII. MAINTENANCE, CLEANING AND SERVICING

### Before each maintenance and cleaning work

1. Stop the engine.
2. Wait until the cutting device stops moving.
3. Remove the cover (14) with the allen key (27).
4. Pull off the spark plug cover (15).

**⚠ WARNING!** Do not carry out maintenance work close to open flames. Risk of fire!

Maintenance and repair work other than those described in this chapter is only allowed to be carried out by service staff.

**For maintaining and cleaning, removed security devices must unconditionally be mounted properly and proved again.**

Use only original parts. Other parts can result in unexpected damages and injuries.

In order to avoid possible injuries wear gloves.

To guarantee a long and reliable usage of the machine carry out the following main-

aintenance works regularly.

### **Check the machine for obvious defects such as**

- loose fastening elements.
- worn or damaged components.
- deformed, broken or damaged cutting blade (8).
- leaks from the fuel tank cap or fuel lines.

### **Cleaning**

- Keep the ventilation vents of the machine clean at all times, if possible, prevent foreign matter from entering the vents.
- After each use, blow air through the motor housing to ensure it is free from all dust particles which may build up. Build up of dust particles may cause the unit to overheat and fail.
- If the enclosure of the tool requires cleaning do not use solvents but a moist soft cloth or soft brush only. Never let any liquid get inside the machine; never immerse any part of the tool into a liquid.

### **Air filter maintenance (Fig. 8)**

1. Open the air filter cover (18).
2. Remove the air filter (B), brush off any dry particles, or dislodge them by tapping the air filter (B) on a hard surface.
3. Mount the air filter (B) and close the air filter cover (18).

### **Checking / replacing the spark plug (Fig. 1 / 9 / 10)**

Remove the cover (14) with the allen key (27).

Do not touch the spark plug or the spark plug cover (15) when the engine runs. High voltage!

Risk of burning on the hot engine. Wear protective gloves.

Check the spark plug and the spark gap on a regular basis:

1. Pull the spark plug cover (15) from the spark plug.
2. Remove the spark plug using the supplied spark plug wrench (26).

The spark gap must be 0.6 to 0.7 mm. **(Fig. 10)**

Clean the spark plug when it is contaminated.

Replace the spark plug:

- once a month if the device is often used



- when the insulating body is damaged,
- when the electrodes show excessive erosion,
- when the electrodes show excessive dirt or oil.

### Changing the cutting blade (Fig. 11)

1. Hold the cutting blade (8) in place with the allen key (27), by putting it in the hole of the spindle. Use the spark plug wrench (26) to remove the flange nut, by turning in an anti-clockwise direction.

2. Remove the flange nut, and cutting blade (8).

**NOTE:** Ensure that all parts are clean of any dirt or grass prior to fitting.

3. Fit the new cutting blade (8) over the inner flange.

4. Fit the flange nut and tighten firmly using the spark plug wrench (26) supplied, in a clockwise direction.

## IX. TECHNICAL DATA

Engine	4-Stroke, 31 cm <sup>3</sup>
Engine power	0.7 kW (1HP)
Engine idling speed	3000±300 min <sup>-1</sup>
Cutting blade speed	2800 min <sup>-1</sup>
Cutting diameter	240 mm
Max. cutting height	40 mm
Tank capacity	0.72 L
Fuel type	Petrol, unleaded
Oil tank capacity	0.1 L
Oil type	SAE 10W-30

Subject to technical changes!

### Wear ear-muffs.

The impact of noise can cause damage to hearing.

### Keep the noise emissions and vibrations to a minimum.

- Only use appliances which are in perfect working order.
- Service and clean the appliance regularly.
- Adapt your working style to suit the appliance.
- Do not overload the appliance.
- Have the appliance serviced whenever necessary.
- Switch the appliance off when it is not in use.
- Wear protective gloves.

### Sound and vibration

Sound pressure level $L_{pA}$	85.7 dB(A)
Uncertainty $K_{pA}$	3 dB(A)
Sound power level $L_{wA}$	106 dB(A)
Uncertainty $K_{wA}$	3 dB(A)
Vibration $a_{hv}$	7.15 m/s <sup>2</sup>
Uncertainty $K_{hv}$	1.5 m/s <sup>2</sup>

## X. STORAGE

**Caution!** Never put the machine into storage for longer than 30 days without carrying out the following steps.

**If you intend to store the equipment for machine than 30 days, it must be prepared accordingly.** Otherwise the fuel still remaining in the carburettor will evaporate and leave a rubbery sediment. This can cause problems when starting up the machine and may require expensive repairs.

1. Slowly remove the fuel tank cap to release any pressure that may have formed in the tank. Carefully empty the tank of fuel.
2. To remove the fuel from the carburettor, start the engine and let it run until the machine stops.
3. Leave the engine to cool (approx. 5 minutes).
4. Store the machine in a dry, locked place out of the reach of children.

**To extend the service life of the machine and guarantee smooth operation, before storing for a longer period:**

- Thoroughly clean the machine.
- Treat all movable parts with an environmentally friendly oil.
- Never use any grease!
- Remove the spark plug cover.
- Empty the fuel tank completely.
- Dispose of remaining fuel in an environmentally compatible manner.
- Operate the engine until the carburettor is empty.

## **XI. TRANSPORT**

To transport the device stop the engine and wait until the cutting blade (8) stops moving.

Tilt the machines backwards at the upper handle (3), so that the cutting blade (8) is clear of the ground and you can move the machine on the two back wheels (6).

## **XII. DISPOSAL AND RECYCLING**

The machine is supplied in packaging to prevent it from being damaged in transit. The raw materials in this packaging can be reused or recycled. The machine and its accessories are made of various types of material, such as metal and plastic. Never place defective equipment in your household refuse. The machine should be taken to a suitable collection center for proper disposal. If you do not know the whereabouts of such a collection point, you should ask in your local council offices.

### XIII. TROUBLESHOOTING

The table below contains a list of fault symptoms and explains what you can do to remedy the problem if your equipment fails to work properly. If the problem still persists after working through the list, please contact your nearest service workshop.

#### ⚠ IMPORTANT!

Hint in case of sending the equipment to a service centre:

Due to safety reasons please see to it that the equipment is sent back free of oil and petrol!

Fault	Possible cause	Remedy
Machine does not work.	<ul style="list-style-type: none"> <li>No fuel supply.</li> <li>Fault in the fuel line.</li> <li>Spark plug defective.</li> <li>Carburettor defective.</li> <li>Internal fault.</li> </ul>	<ul style="list-style-type: none"> <li>Check the fuel quantity. DO NOT USE FUEL WITH ETHANOL MIXTURE.</li> <li>Check the fuel line for kinks or damages.</li> <li>Replace the spark plug.</li> <li>Manufacturer or responsible customer service must be called.</li> <li>Manufacturer or responsible customer service must be called.</li> </ul>
Machine does not switch off.	<ul style="list-style-type: none"> <li>ON/OFF switch defective.</li> </ul>	<ul style="list-style-type: none"> <li>Let the machine run, till the petrol is exhausted. Manufacturer or responsible customer service must be called.</li> </ul>
Machine work with interruptions.	<ul style="list-style-type: none"> <li>Internal fault.</li> <li>ON/OFF switch defective.</li> </ul>	<ul style="list-style-type: none"> <li>Manufacturer or responsible customer service must be called.</li> <li>Manufacturer or responsible customer service must be called.</li> </ul>
Engine is running, cutting blade does not move.	<ul style="list-style-type: none"> <li>Cutting blade blocked.</li> <li>Internal fault.</li> <li>Clutch defective.</li> </ul>	<ul style="list-style-type: none"> <li>Remove object.</li> <li>Manufacturer or responsible customer service must be called.</li> <li>Manufacturer or responsible customer service must be called.</li> </ul>





GARDEN LAWN EDGER  
**Warranty Details**

---

REGISTER YOUR PURCHASE AT [www.aldi.com.au/en/about-aldi/product-registration/](http://www.aldi.com.au/en/about-aldi/product-registration/) TO KEEP UP-TO-DATE WITH IMPORTANT PRODUCT INFORMATION

---

The product is guaranteed to be free from defects in workmanship and parts for a period of 36 months from the date of purchase. Defects that occur within this warranty period, under normal use and care, will be repaired, replaced or refunded at our discretion. The benefits conferred by this warranty are in addition to all rights and remedies in respect of the product that the consumer has under the Competition and Consumer Act 2010 and similar state and territory laws.

Our goods come with guarantees that cannot be excluded under the Australian Consumer Law. You are entitled to a replacement or refund for a major failure and for compensation for any other reasonably foreseeable loss or damage. You are also entitled to have the goods repaired or replaced if the goods fail to be of acceptable quality and the failure does not amount to a major failure.

---

**AFTER SALES SUPPORT**

  **1300 855 831**  
27

 [support@scheppach.com.au](mailto:support@scheppach.com.au)  
MODEL:LE3200P PRODUCT CODE: 10102 08/2019







GARDEN LAWN EDGER

## Repair and Refurbished Goods or Parts Notice

---

Unfortunately, from time to time, faulty products are manufactured which need to be returned to the Supplier for repair.

Please be aware that if your product is capable of retaining user-generated data (such as files stored on a computer hard drive, telephone numbers stored on a mobile telephone, songs stored on a portable media player, games saved on a games console or files stored on a USB memory stick) during the process of repair, some or all of your stored data may be lost.

**We recommend you save this data elsewhere prior to sending the product for repair.**

You should also be aware that rather than repairing goods, we may replace them with refurbished goods of the same type or use refurbished parts in the repair process.



**Please be assured though, refurbished parts or replacements are only used where they meet ALDI's stringent quality specifications.**

If at any time you feel your repair is being handled unsatisfactorily, you may escalate your complaint. Please telephone us on 1300 855 831 or write to us at:

RossMac Pty. Ltd.  
P.O. Box 261, Essendon North, Victoria, 3041  
1300 855 831  
[support@schepach.com.au](mailto:support@schepach.com.au)

---

AFTER SALES SUPPORT

  1300 855 831

29

 [support@schepach.com.au](mailto:support@schepach.com.au)

MODEL:LE3200P PRODUCT CODE: 10102 08/2019

3

YEAR WARRANTY





