

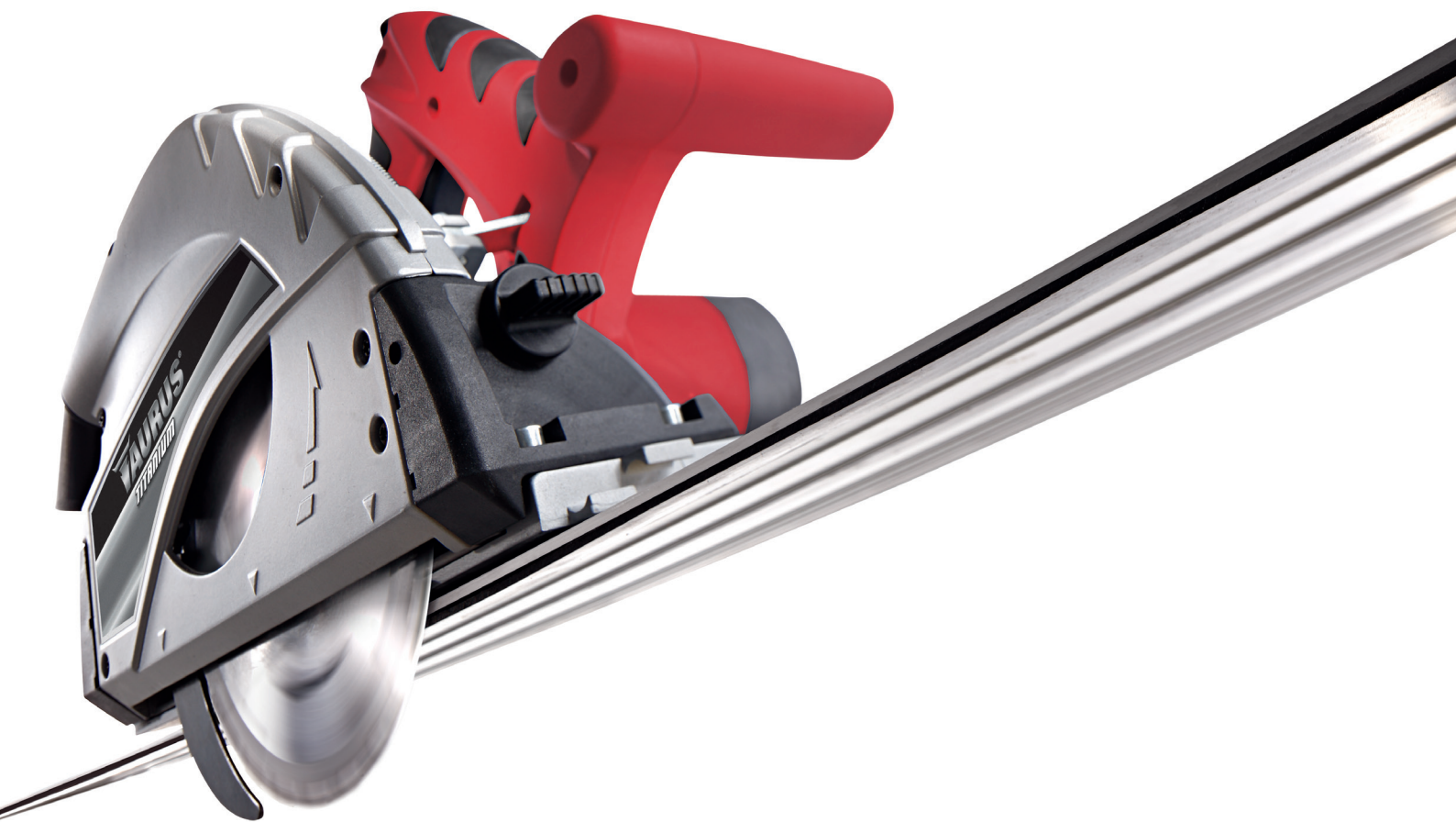

## ***PLUNGE SAW***



***INSTRUCTION MANUAL    MODEL NUMBER 43898***

***AFTER SALES SUPPORT***

***TEL: 1300 130 579***

***WEB: [www.support@schepach.com.au](http://www.support@schepach.com.au)***



**5490**

**MADE IN CHINA**

# Plunge Saw

1

## What your 3 year warranty means

Great care has gone into the manufacture of this product and it should therefore provide you with years of good service when used properly. In the event of product failure within its intended use over the course of the first 3 years after the date of purchase, we will remedy the problem as quickly as possible once it has been brought to our attention. In the unlikely event of such an occurrence, or if you require any information about the product please contact us via our after sales support services, details of which can be found in this manual and on the product itself.

## INDEX:

Pictures	Page 3
General Notes	Page 4
General Safety Instructions for Power Tools	Page 5
Safety Instructions for all saws	Page 6
Additional safety instructions for all saws	Page 6
Safety instructions for inserted circular saw use	Page 6
Additional safety instructions for all sawing with a wedge	Page 7
Special Safety Instructions	Page 7
Proper use	Page 7
Remaining hazards	Page 7
Suitable use	Page 8
Start-up	Page 8
Adjusting	Page 8
Operations	Page 8
Electrical connection	Page 9
Maintenance	Page 10
Trouble shooting	Page 11
Pictures	Page 12
Accessories	Page 13
Warranty Details	Page 15
Repair and Refurbished Goods or Parts Notice	Page 16

Fig. 1

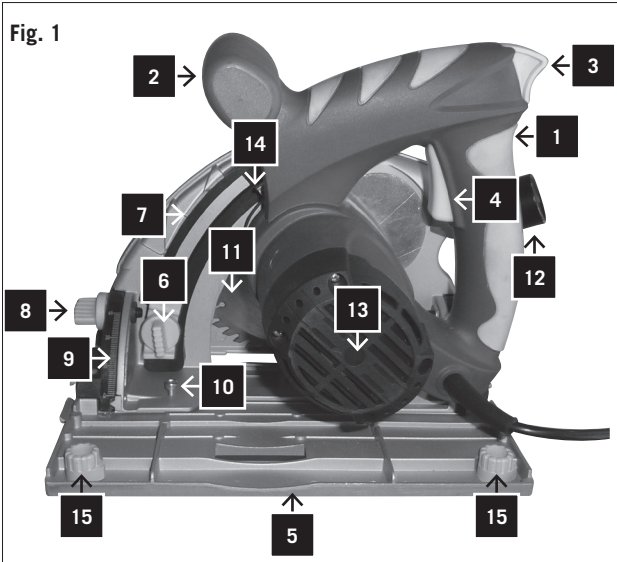

Fig. 2

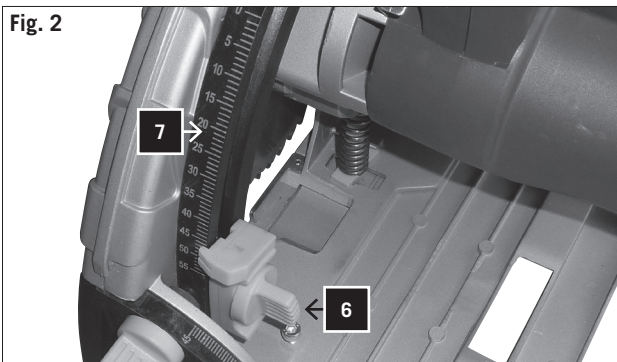

Fig. 3

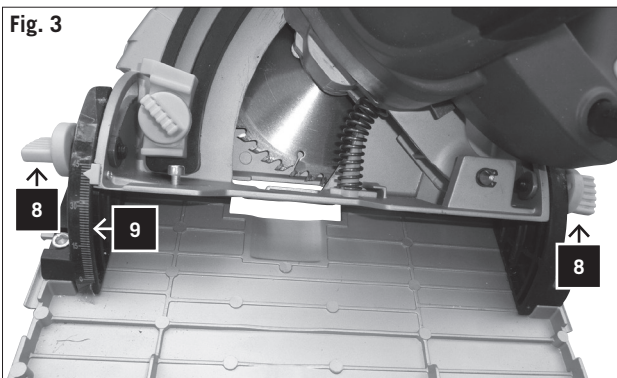

Fig. 4

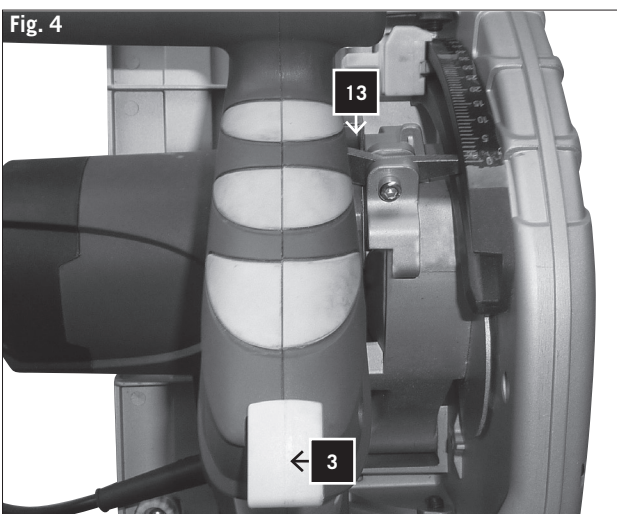

Fig. 5

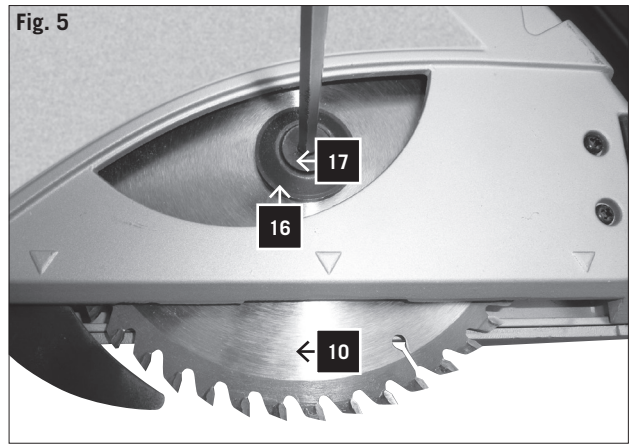

Fig. 6

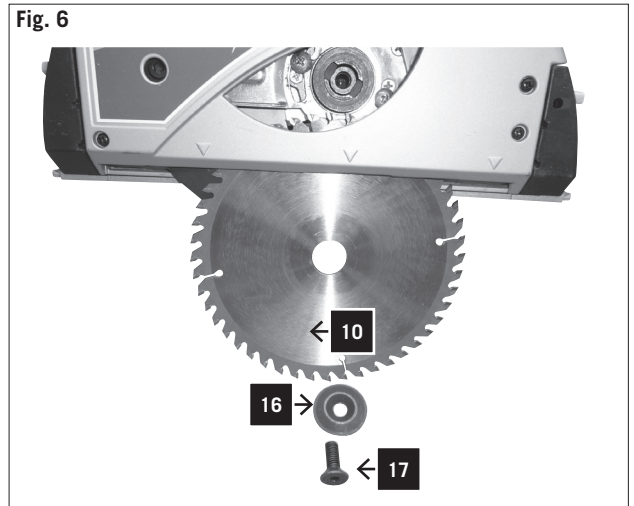

Fig. 7

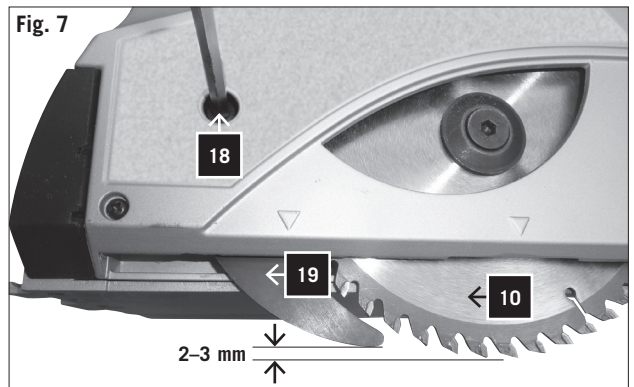

Fig. 8

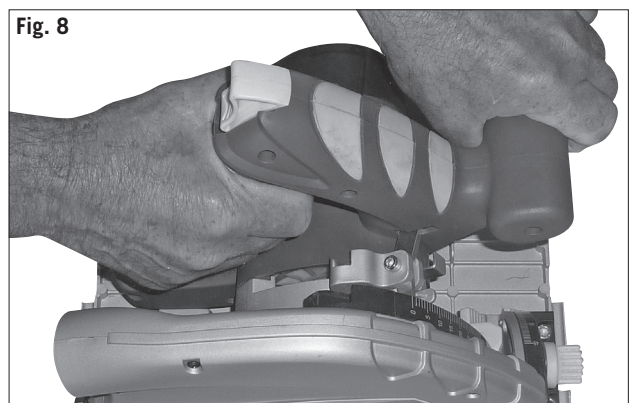
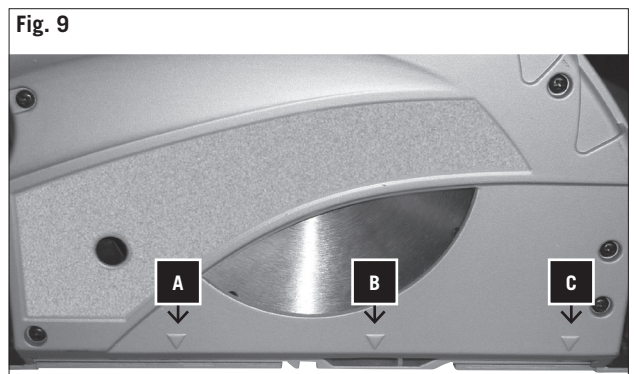

Fig. 9



Congratulations on choosing to buy a TAURUS TITANIUM® product. All products brought to you by TAURUS TITANIUM® are manufactured to the highest standards of performance and safety, and, as part of our philosophy of customer service and satisfaction, are backed by our comprehensive 3 Year Warranty. We hope you will enjoy using your purchase for many years to come.

**NOTE:**

According to the applicable product liability law the manufacturer of this device is not liable for damages which arise on or in connection with this device in case of:

- improper handling,
- non-compliance with the instructions for use,
- repairs by third party, non authorized skilled workers,
- installation and replacement of non-original spare parts,
- improper use,
- failures of the electrical system due to the non-compliance with the electrical specifications and the VDE 0100, DIN 57113 / VDE 0113 regulations

**RECOMMENDATIONS:**

Read the entire text of the operating instructions prior to the assembly and operation of the device.



These operating instructions are intended to make it easier for you to get familiar with your device and utilize its intended possibilities of use.

The operating instructions contain important notes on how to work safely, properly and economically with your machine and how to avoid dangers, save repair costs, reduce downtime, and increase the reliability and working life of the machine.

In addition to the safety regulations contained herein, you must in any case comply with the applicable regulations of your country with respect to the operation of the machine.

Put the operating instructions in a clear plastic folder to protect them from dirt and humidity, and store them near the machine. The instructions must be read and carefully observed by each operator prior to starting the work. Only persons who have been trained in the use of the machine and have been informed on the related dangers and risks are allowed to use the machine. The required minimum age must be met.

In addition to the safety notes contained in the present operating instructions and the special regulations of your country, the generally recognized technical rules for the operation of wood working machines must be observed.

	Read the operating instructions before beginning work with this power tool.
	Wear ear and eye protection.

	Wear breathing protection.
---	----------------------------

**LEGEND - FIG. 1**

- 1 Handle/hand grip
- 2 Front handle
- 3 Plunge-cut trigger
- 4 On/off switch
- 5 Base plate
- 6 Adjustment screw for depth of cut
- 7 Scale for depth of cut
- 8 Mitre adjustment screw
- 9 Mitre square
- 10 90-degree adjustment screw
- 11 Saw blade
- 12 Suction nozzle
- 13 Motor
- 14 Shaft locking mechanism
- 15 Adjustment screw for guide rail

PL 55	
<b>Scope of delivery</b>	
	Plunge Saw
	Hexagon head wrench 5mm
	Operating instructions
	2 Guide Rails
	Guide Track Connector
	Saw Blade
	Tilt Safety Device
	Allen Key
<b>Technical Data</b>	
<b>Dimensions L x W x H mm</b>	340 x 260 x 235
<b>Saw blade ø mm / number of teeth</b>	160 / 24Z
<b>Thickness of saw blade</b>	2,0 mm
<b>Idling speed n0</b>	5500 1/min
<b>Mitre square</b>	0°-45°
<b>Depth of cut 90° mm</b>	55
<b>Depth of cut 45° mm</b>	41
<b>Weight kg</b>	8,2
<b>Drive</b>	
<b>Motor V/Hz</b>	230-240/50
<b>Input W</b>	1200
<b>Protection class</b>	II
<b>Operating noise level and vibrations</b>	
<b>Sound pressure level</b>	$L_{pA}$ : 95 dB(A), $K_{pA}$ : 3 dB(A)
<b>Sound power level</b>	$L_{wA}$ : 106 dB(A), $K_{wA}$ : 3 dB(A)
<b>Typical weighted vibrations</b>	$a_h = 5,72 \text{ m/s}^2$ , $K = 1,5 \text{ m/s}^2$
<b>Measured values corresponding to EN 60 745-2-5 and EN 60 745-1</b>	
<b>Subject to technical modifications!</b>	

**Warning:** Noise can have adverse health effects. Should the noise level increase above 85 dB(A), you must wear ear protection. Should the electrical supply not be optimal, then the current can drop for a short time when the machine is turned on. This can influence other equipment (for example, the blinking of a lamp). Should the electrical capacity have a  $Z_{max} < 0.27$ , such disturbances are not to be expected. (Should you have difficulties, please consult your local dealer.)

## General notes

- After unpacking, check all parts for any transport damage. Inform the supplier immediately of any faults.
- Later complaints cannot be considered.
- Make sure the delivery is complete.
- Before putting into operation, familiarize yourself with the machine by carefully reading these instructions.
- Use only original Taurus Titanium® accessories, wearing or replacement parts. You can find replacement parts by contacting the after sales support number on 1300 130 579.
- When ordering, include our item number and the type and year of construction of the machine.

In these operating instructions we have marked the places that have to do with your safety with this sign: ⚠

### ⚠ General safety instructions for power tools

- **WARNING Read all warnings and instructions.** Failure to apply all warnings and instructions can lead to electrical shock, fire and/or serious injury.
- **Keep all warnings and instructions handy for future consultation.**
- **The term “power tool” used in the warnings refers to power tools that are connected to a source of electrical energy (with an electrical cable)**

#### 1) Workplace safety

- a) Keep your working area clean and well lit. Cluttered or dimly lit workspaces can lead to accidents.
- b) Do not operate power tools in areas where explosions could take place, or in which flammable liquids, gases or dust are present. Power tools can create sparks, which can cause dust or fumes to ignite.
- c) Keep children and bystanders away from the power tool when it is being used. Distractions could cause you to lose control over the equipment.

#### 2) Electrical safety

- a) The terminal plug of the tool must fit into the outlet. The plug may not be modified in any way. Do not use an adaptor plug together with grounded power tools. The original plugs and the appropriate outlets reduce the risk of an electrical shock.
- b) Avoid contact with grounded surfaces, such as pipes, radiators, stoves and refrigerators. There is an increased risk of electrical shock, if your body is grounded.
- c) Keep power tools away from rain or wet conditions. Penetration of water into the power tool increases the risk of electrical shock.
- d) Do not use the cable for any purpose other than that for which it was made. Do not use it to carry the tool, hang it up, or to pull the plug out of the outlet. Keep the cable away from heat, oil, sharp corners or parts of the equipment that move. Damaged or entangled cords increase the risk of electrical shock.
- e) When operating the power tool outdoors, only use extension cords that are suitable for outdoor use. The use of an appropriate extension cord reduces the risk of an

electrical shock.

f) If the power tool must be used in a damp environment, use a residual current protective device. The use of such a device reduces the risk of electrical shock.

#### 3) Personal safety

- a) Be attentive, watch what you are doing and use the power tool sensibly. Do not use power tools when you are tired or under the influence of drugs, alcohol or medicines. One moment of inattention while using a power tool can result in serious injury.
- b) Wear personal protective equipment and always wear protective glasses. Wearing personal protective equipment, such as a dust mask, slip-free safety shoes, protective headwear or ear protection, depending on the type and use of a power tool reduces the risk of injury.
- c) Avoid unintentional start-ups. Make sure that the power tool is shut off before it is connected to the power supply, or is carried. If you have your finger on the switch of the tool while carrying it, or have the tool turned on, or connected to a power supply, this behaviour can lead to accidents.
- d) Remove the adjustment aides or the spanners before turning on the power tool. A tool or wrench that is located in a rotating part of the machine, can lead to injuries.
- e) Avoid abnormal posture. Make sure that the operator is standing firmly and can maintain balance. This allows the operator to maintain control over the power tool in unexpected situations.
- f) Wear appropriate clothing. Do not wear loose clothing or jewellery. Keep hair, clothing and gloves away from the moving parts. Loose clothing, jewellery or long hair can get caught in the moving parts.
- g) If dust vacuums or catching systems can be installed on the tool, make sure that these are correctly connected and assembled. The use of a dust exhaust unit can reduce hazards caused by dust.

#### 4) Use and treatment of the power tool

- a) Do not overtax the tool. Use the appropriate tool for the work that is to be done. With the correct power tool, you can work better and more safely.
- b) Do not use a power tool where the switch is defective. A power tool that cannot be turned on and off is dangerous and must be repaired.
- c) Disconnect the plug from the wall outlet before you make adjustments to the tool, change parts or put the tool away. This precaution prevents inadvertent start-ups of the tool.
- d) Store power tools that are not in use out of reach of children. Do not let anyone use the tool who does not have experience with it, or who has not read these instructions. Power tools can be dangerous when they are used by inexperienced people.
- e) Take good care of your power tools. Make sure that movable parts function properly and do not jam, see that parts which influence the use of the machine are not broken or damaged. Repair damaged parts before operating the tool. Many accidents are caused by poorly maintained power tools.
- f) Keep cutting edges sharp and clean. Properly maintained cutting tools with sharp cutting edges jam less often

and are easier to control.

g) Use power tools, accessories, and equipment according to these instructions. Taking into account the working conditions and the work being performed.

The use of power tools other than those intended for the tool itself can lead to dangerous situations.

#### 5) Service

a) Only let qualified service personnel repair your tool and always use original replacement parts. This guarantees that the power tool remains safe to use.

### ⚠ Safety instructions for all saws

a) DANGER: Do not put your hands in the sawing area or on the saw blade. Keep your second hand on the extra handle of the motor housing. If both hands are holding the saw, neither can be injured by the saw blade.

b) Do not put your hands under the work piece. The protective cap cannot protect your hands from the blade when they are under the work piece.

c) Adjust the cutting depth to the thickness of the work piece. Less than one complete sawing tooth should be visible under the work piece.

d) Never hold the work piece that is to be sawn in your hand or over your leg. Make sure that the work piece has a stable balance. It is important that the work piece is held securely, in order to minimize the danger of contact of a body part with the saw, loss of control over the saw, or jamming of the blade.

e) Hold the equipment on the insulated handles, when you undertake work in which the tool being used could come into contact with hidden electrical wires, or its own cable. Contact with a live power source can electrify the metal parts of the tool and lead to an electrical shock.

f) When making a long cut, always use a stop chock or a straightedge. This improves the accuracy of the cut and reduces the chance that the saw blade jams.

g) Always use the correct size of saw blades and make sure they have the right locating bore (e.g. Star shaped or round). Saw blades that do not fit the assembly of the saw do not run correctly and cause loss of control.

h) Never use damaged or incorrect saw blade shims or screws.

The saw blade shims and screws are designed especially for your saw, for optimal performance and operating safety.

### ⚠ Additional safety instructions for all saws

Causes and prevention of kickbacks:

- A kickback is a sudden reaction due to a caught, jammed or incorrectly adjusted saw blade, which leads to the saw rearing up in an uncontrolled manner and moving out of the work piece towards the operator.
- If a saw blade catches or jams in the sawing edge that closes behind it, it is blocked and motor's drive pushes the saw back in the direction of the operator.
- If the saw blade twists in the saw groove or is incor-

rectly positioned, the teeth at the rear side of the saw blade edge catch in the surface of the work piece. The saw then moves out of the saw groove and springs back in the direction of the operator.

• A kickback results from an incorrect or faulty use of the saw. It can be prevented, as will be described in the following, by appropriate cautionary measures.

a) Hold onto the saw with both hands and position your arms so that they can absorb any energy from a kickback. Always keep to the side of the saw blade, and never bring it into line with your body. In the case of a kickback, the circular saw can jump backwards, but with adequate caution the operator can deal with the energy of the kickback.

b) If the saw blade jams or you want to interrupt your work, then turn the saw off and keep the work piece still until the saw blade comes to a full stop. Never try to remove the saw from the work piece or pull it out when the saw blade is moving since then a kickback can occur. Find out the cause of the jam and remove it.

c) If you want to start up a saw that is in the work piece, centre the saw blade in the sawed groove and check that the saw blade teeth are not caught in the work piece. If the saw blade is jammed, it can jump out of the work piece or cause a kick back when it is started up.

d) Support larger work pieces in order to reduce the risk of a kick back due to a saw blade jam. The weight of larger work pieces can cause them to bend. Large pieces must be supported on both sides, both near the sawing slot as well as on the edges.

e) Do not use dull or damaged saw blades. Saw blades with dull or misaligned teeth increase the friction, in the sawing slot, cause saw blade jams and kickbacks.

f) Before you start sawing, tighten the adjustments for the cut depth and angles. If you change settings while sawing, the saw blade can jam and a kickback is the result.

g) Be particularly careful when making "inserted cuts" in walls that already exist or other areas where you cannot see what is behind the surface. When the saw blade is inserted into the wall it can be blocked by hidden objects and cause a kick back.

### ⚠ Safety instructions for inserted circular saw use

a) Each time before you use the saw, make sure that the protective covering closes. Do not use the saw if the protective covering cannot move freely and does not close immediately. Never clip or tie the protective covering in an opened position. If the saw should accidentally fall to the ground, the protective covering can get bent. Make sure that the protective covering can move freely and does not touch the saw blade or other parts in all cutting positions.

b) Check the condition and function of the spring for the protective covering. Have the saw repaired before use if the protective covering and spring do not work perfectly. Damaged parts, sticky residuals or piles of saw dust can interfere with the working of the lower protective cover.

c) When making an “inserted cut” that does not describe a right angle, make sure that the saw is guarded against slipping to the side. Slippage can lead to a saw blade jam and a kickback.

d) Do not put the saw on the workbench or the floor without making sure that the protective cover is over the saw blade. An unprotected, running saw blade can move the saw against the cutting direction and saw what is in the way. Check the delay time of the saw.

### ⚠ Additional safety instructions for all sawing with a wedge

a) Use the right wedge for the saw blade that is in use. The wedge must be thicker than the thickness of the steel blade but thinner than the width of the teeth.

b) Adjust the wedge as described in the operating instructions. Incorrect thickness, position or direction can be the reason that the wedge does not effectively prevent a kickback.

c) Always use a wedge, except when making an inserted cut. Reassemble the wedge after an inserted cut. The wedge is in the way when making an inserted cut and can cause a kickback.

d) In order for the wedge to be effective, it must be in the sawing gap. For short cuts, a wedge does not work to prevent kickbacks.

e) Never run the saw with a bent wedge. Even the smallest defect can slow down the closing of the protective cover.

### INSTRUCTIONS FOR ALL SAWS

- Do not use a sanding belt.
- Make sure that the wedge is adjusted so that the distance to the sprocket ring of the saw blade is not more than 5 mm and that the sprocket ring does not stick out more than 5 mm above the lower edge of the wedge.
- Make sure that the dust catching mechanism is correctly installed, as is described in this manual.
- Wear breathing protection.
- Only those saw blades recommended in the manual should be used.
- Always wear ear protection.
- Replace the saw blades as described in this manual.
- The maximum cut depth is 55 mm.

If the electrical cable of this tool is damaged it must be replaced by the manufacturer or the customer service department or a similarly qualified specialist in order to avoid dangers.

### FURTHER SPECIAL SAFETY INSTRUCTIONS FOR CIRCULAR SAWS

a) Only use the recommended saw blades which correspond to EN 847-1.

b) Do not use sanding belts.

c) Only use the manufacturer's original saw blades with the number Ø 160 mm, 5500/min, 160 x 20 x 2.0.

Do not use any saw blades which do not correspond to the characteristics described in these operating instructions. Saw blades may not be brought to a stop by pressure on the machine from the side.

Make sure that the saw blade is tightly assembled and turns in the correct direction.

### ⚠ Special Safety Instructions

Safety instructions for circular saws

- Hold the equipment on the insulated handles, when you undertake work in which the tool being used could come into contact with hidden electrical wires, or its own cable. Contact with a live power source can electrify the metal parts of the tool and lead to an electrical shock.

### ⚠ Proper use

**CE tested machines meet all valid EC machine guidelines as well as all relevant guidelines for each machine.**

- The machine must only be used in technically perfect condition in accordance with its designated use and the instructions set out in the operating manual, and only by safety-conscious persons who are fully aware of the risks involved in operating the machine. Any functional disorders, especially those affecting the safety of the machine, should therefore be rectified immediately.
- Any other use exceeds authorization. The manufacturer is not responsible for any damages resulting from unauthorized use; risk is the sole responsibility of the operator.
- The safety, work and maintenance instructions of the manufacturer as well as the technical data given in the calibrations and dimensions must be adhered to.
- Relevant accident prevention regulations and other, generally recognized safety-technical rules must also be adhered to.
- The machine may only be used, maintained, and operated by persons familiar with it and instructed in its operation and procedures. Arbitrary alterations to the machine release the manufacturer from all responsibility for any resulting damages.
- The machine may only be used with original accessories and tools made by the manufacturer.
- The machine may not be operated with sanding belts.

### ⚠ Remaining hazards

**The machine has been built using modern technology in accordance with recognized safety rules. Some remaining hazards, however, may still exist.**

- The use of incorrect or damaged mains cables can lead to injuries caused by electricity.
- Even when all safety measures are taken, some remaining hazards which are not yet evident may still be present.
- ‘Remaining hazards can be minimized by following the instructions in “Safety Precautions”, “Proper Use“ and in the entire operating manual.’



- Do not force the machine unnecessarily: excessive cutting pressure may lead to rapid deterioration of the blade and a decrease in performance in terms of finish and cutting precision.
- When cutting aluminium and plastics always use the appropriate clamps: all workpieces must be clamped down firmly.
- Avoid accidental starts: do not press the start button while inserting the plug into the socket.
- Always use the tools recommended in this manual to obtain the best results from your plunge cut saw.
- Always keep hands away from the work area when the machine is running; before performing tasks of any kind release the main switch button located on the handgrip, thus disconnecting the machine.

## ⚠ Suitable use

### To cut:

- Hard and soft, domestic and exotic wood both longitudinally and transversally and with appropriate adjustments (specific blade and clamps);

### Unsuitable use

#### Do not cut:

- Ferrous materials, steel and cast iron or any other material not mentioned above and in particular foodstuffs.

## Start-up

Observe the safety notes in the operating instructions before operating the machine.

### REMOVAL OF PACKAGING

Remove the box used to protect the machine during transportation and keep it intact for future transportation and storage.

### ELECTRICAL CONNECTIONS

Check that the electrical system to which the machine is connected is earthed in compliance with current safety regulations and that the current socket is in perfect condition.

The electrical system must be fitted with a magnetothermal protective device to safeguard all conductors from short circuits and overload.

The selection of this device should be in line with the following electrical specifications of the machine stated on the motor.

**NOTE:** Your plunge cut saw's electrical system is equipped with an undervoltage relay which automatically opens the circuit when the voltage falls below a minimum pre-established limit and which prevents the self-reset of machine functions when voltage returns to normal levels.

If the machine stops involuntarily, do not be alarmed. Make sure that there has not been a voltage failure in the electrical system.

## ADJUSTING

Caution: Prior to carrying out one of the following adjust-

ment steps, switch the machine off and unplug the mains plug.

### Cutting depth adjustment, Fig. 2

The cutting depth can be adjusted from 0 to 55 mm.

Unfasten the cutting depth adjustment screw (6) and set the required depth using the scale (7) and retighten the screw.

The dimensions on the rail shows the cutting depth without rail.

### Mitre settings, Fig. 3

The mitre square can be set from 0° to 45°.

Unfasten the mitre adjustment screws (8) on both sides, set the desired mitre square on the scale (9) and retighten both screws.

### Saw blade replacement, Fig. 4, 5, 6

**Caution: Before you are going to make the saw blade change, switch off the machine and unplug the power cord.**

- 1 Press the plunge trigger (3), bring the saw blade into the blade-change position (Adjustment screw for depth of cut shall be adjusted to 25mm) and insert the hex wrench into the blade locking screw (17).
- 2 Press on the shaft lock (13) and rotate the saw blade (10) until the lock clicks into place.
- 3 Hold down the locking shaft (13) and open the blade locking screw (17) counter clockwise, while keeping the blade in the blade-changing position.
- 4 Remove the outer flange (16) and the saw blade (10).  
**(Caution: risk of injuries, wear protective gloves)**
- 5 Insert the new blade and flange.
- 6 Screw in and tighten the saw blade locking screw while keeping the shaft locking mechanism pressed again.
- 7 Set the plunge saw to its original position.

### Adjusting the splitting wedge, Fig. 7

Adjust the distance between saw blade and splitting wedge after a saw blade replacement, or whenever necessary.

Put the saw in the same position as you do when replacing a saw blade.

Unfasten the adjustment screw (18) using an Allen key and set the splitting wedge 2-3 mm higher than the saw blade, then retighten the adjustment screw.

## Operations

After having performed all the above procedures and operations, you may begin cutting.

**ATTENTION:** Always keep hands away from the cutting area and do not try to approach it when the machine is running.

### Switching the product on/off, Fig. 1

To switch the plunge-cut saw on, press the on/off switch (4). To switch off, release the on/off switch (4).

### Operating and holding the plunge-cut saw, Fig. 8

- 1 Secure the work piece so that it cannot get displaced or moved while sawing.
- 2 Only move the saw forwards.
- 3 Grip the saw tightly with both hands ensuring that one

hand is placed on the main handle and the other on the front handle.

- 4 When using a guide rail, it must be fastened with screw clamps.
- 5 Make sure the power cable is not placed in the sawing direction.

#### **Sawing**

- 1 Place the front part of the machine onto the work piece.
- 2 Switch the machine on using the on/off switch (4).
- 3 Press the plunge-cut trigger (3).
- 4 Push the saw downwards to reach the sawing depth.
- 5 Push the saw forward evenly.
- 6 After finishing the sawing cut, switch the machine off and move the saw blade upwards.

#### **Plunge-cuts, Fig. 9**

- 1 Place the saw onto the work piece.
- 2 Place the cutting indicator with the rear arrow (A) on the marked plunge-cut position.
- 3 Switch the machine on and push the saw downwards until you reach the set cutting depth.
- 4 Move the saw forwards until the cutting indication (C) has reached the marked point.
- 5 After completion of the plunge-cut, move the saw blade upwards and switch the saw off.

#### **Cutting with rails (optional)**

- 1 Place the machine in the guide rails. can be readjusted using the hex driver included in the delivery, when there is the risk of the adjusting screws releasing by themselves.
- 2 Turn on the machine by pressing the on/off switch (4).
- 3 Press the dip trigger (3).
- 4 Press the saw downwards to reach the sawing depth. During first use the rubber lip is sawn off and thus splitter protection is guaranteed up to the saw blade.
- 5 Push the saw uniformly forwards.
- 6 Turn off the machine and tilt the saw blade to the top when the saw cutting is complete.

#### **Sawing with dust suction**

Connect the suction hose to the exhaust nozzle - Ø 38 mm (12).

### **⚠ Electrical connection**

**The installed electric motor is completely wired ready for operation.**

**The customer's connection to the power supply system, and any extension cables that may be used, must conform with local regulations.**

#### **Important remark:**

The motor is automatically switched off in the event of an overload. The motor can be switched on again after a cooling down period that can vary.

#### **Defective electrical connection cables**

Electrical connection cables often suffer insulation damage.

Possible causes are:

- Pinch points when connection cables are run through window or door gaps.
- Kinks resulting from incorrect attachment or laying of the connection cable.
- Cuts resulting from running over the connecting cable.
- Insulation damage resulting from forcefully pulling out of the wall socket.
- Cracks through aging of insulation.

Such defective electrical connection cables must not be used as the insulation damage makes them **extremely hazardous**.

Check electrical connection cables regularly for damage. Make sure the cable is disconnected from the mains when checking.

Electrical connection cables must comply with the regulations applicable in your country.

#### **Single-phase motor**

- The mains voltage must coincide with the voltage specified on the motor's rating plate.
- Extension cables up to a length of 25 m must have a cross-section of 1.5 mm<sup>2</sup>, and beyond 25 m at least 2.5 mm<sup>2</sup>.
- The connection to the mains must be protected with a 16 A slow-acting fuse.

Only a qualified electrician is permitted to connect the machine and complete repairs on its electrical equipment.

In the event of enquiries please specify the following data:

- Motor manufacturer
- Type of current of the motor
- Data recorded on the machine's rating plate
- Data recorded on the switch's rating plate

If a motor has to be returned, it must always be dispatched with the complete driving unit and switch.

## Maintenance

**If specialist personnel must be brought in for extraordinary service or repairs during the warranty period and thereafter, please contact a service provider recommended by us or contact the manufacturer directly.**

- Overhauls, maintenance work, cleaning, as well as the elimination of any malfunctions must only be undertaken after turning off the motor.
- All protective and safety equipment must be reinstalled immediately upon completion of any repair or maintenance work.

### **REGULAR MAINTENANCE**

The regular maintenance described above and in the paragraph below can be carried out by unskilled personnel.

- Do not oil the plunge cut saw, cause cutting must be carried out in dry conditions; all rotating parts are self-lubricating.
- During maintenance, wear protective gear if possible (accident-prevention goggles and gloves).
- Remove cuttings when necessary both from the cutting area, work surfaces and support bases.  
Use of an aspirator or brush is recommended.

**ATTENTION:** Do not use compressed air jets!

- Regularly check blade conditions: if difficulties should arise during cutting, have it sharpened by skilled personnel or replace it if necessary.

### **ASSISTANCE**

When in need of skilled personnel for special maintenance, or for repairs, both during and following the guarantee period, always apply to authorized centres for assistance or directly to the manufacturer if there is no authorized centre in your area.

### **DISPOSAL OF THE MACHINE.**

Once its operating activity is finished, the disposal of the machine must take place through a normal collection and disposal Center for industrial waste.

## Trouble shooting

Problem	Possible Cause	Help
The motor does not run.	Faulty motor, power supply cable or plug. Burned out fuses.	Have the machine checked by skilled personnel. Do not try to repair the machine yourself as it may be dangerous. Check the fuses and replace them if necessary.
The motor starts slowly and does not reach running speed.	Low power supply voltage. Damaged windings. Burned out capacitor.	Ask for the Electricity Board to check the voltage available. Have the machine motor checked by skilled personnel. Have the capacitor replaced by skilled personnel.
Excessive motor noise.	Damaged windings. Faulty motor.	Have the motor checked by skilled personnel.
The motor does not reach full power.	Overloaded circuit due to lighting, utilities or other motors.	Do not use other utilities or motors on the circuit to which the plunge cut saw is connected.
Motor overheats easily	Overload of the motor; inadequate cooling of the motor	Prevent overloading the motor when cutting; remove dust from the motor to ensure an optimum cooling of the motor
Decrease in cutting power when sawing	The saw blade is too small (sharpened too often)	Re-adjust the end stop of the saw unit
The saw cut is rough or wavy	The saw blade is dull; the tooth shape is not suited to the thickness of the material	Re-sharpen the saw blade or use an appropriate saw blade
The work piece rips or splinters	The cutting pressure is excessive or the saw blade is not suited to the application	Use the correct saw blade

Fig. 1.1

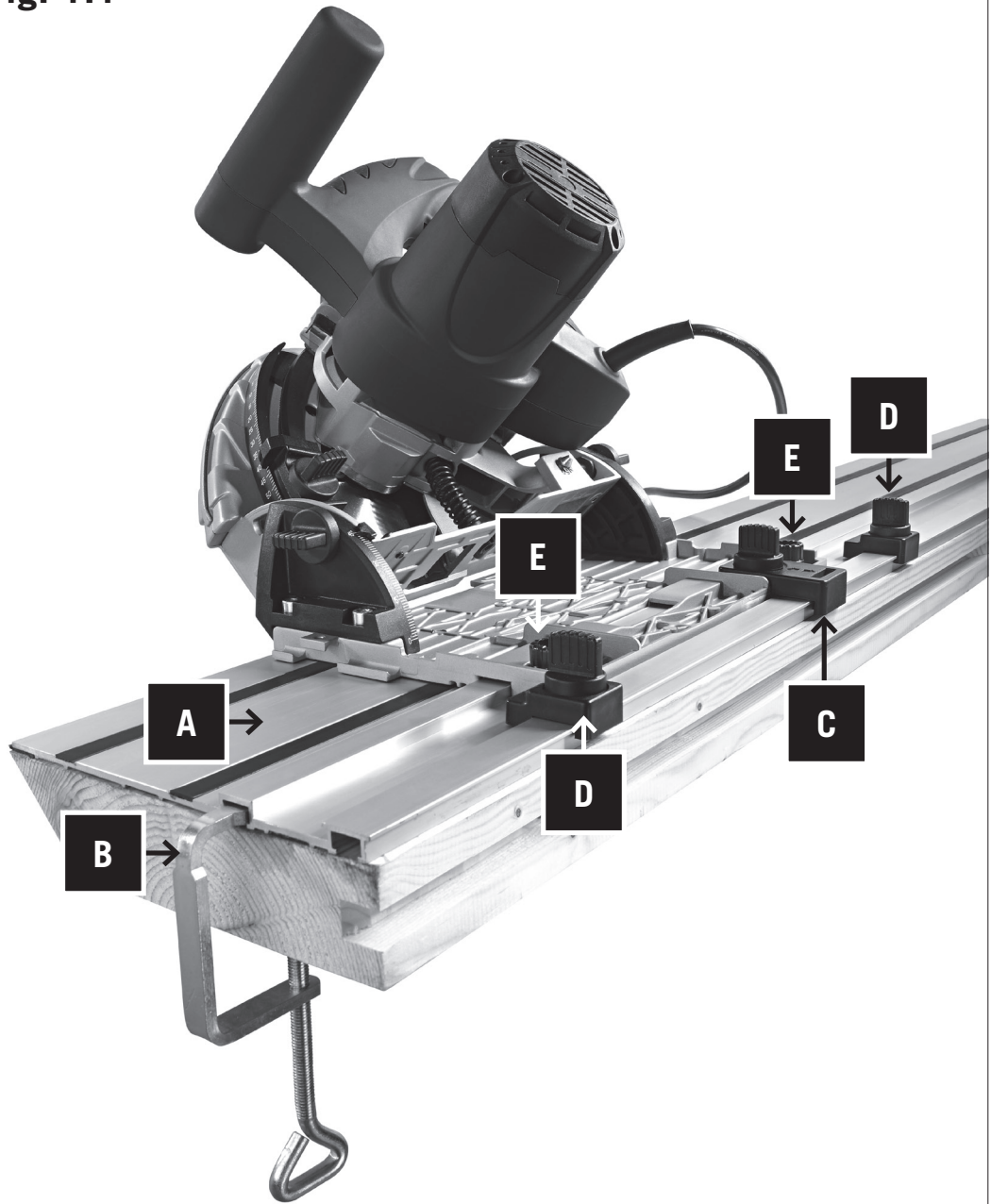
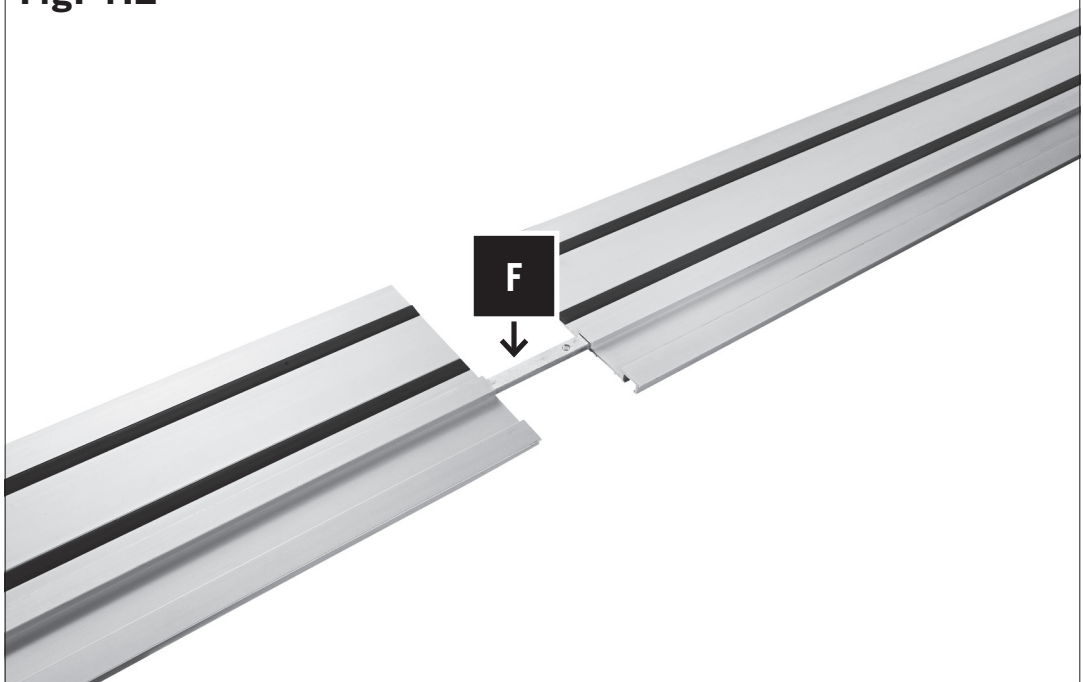

Fig. 1.2



## ACCESSORIES

### Guide System

#### 2 Pieces Guide Rail 700 mm

#### 1 Piece Rail Joiner

### Guide Device (Fig. 1.1, 1.2)

The guide rails (A) enable clean, precise cuts and protect the surfaces from damage.

When sawing with the guide rail, the cut depth is 4.5 mm less than the scale value on the machine.

For safety, the guide rail can be secured with screw clamps (B).

The tilt protection (C) prevents the plunge saw from tilting during mitre cuts and adjustment work.

The rebound protection (D) ensures a safe guiding during plunging into the workpiece.

By means of the rail joiner (F), 2 guide rails can be connected and allow long, precise cuts

The guide clearance of the assembly on the guide rail can be regulated with the two adjustment screws (E).

With the offered accessories, mitre cuts, corner cuts and other fitting tasks can be carried out.

When first using this saw on the optional guide rail, it will need to be adjusted to slide with minimal side movement on the guide rail, Adjustable cams (Fig 1.1 "E") are fitted to do this.

1. Place saw on guide rail.
2. Turn cams (Fig 1.1 "E") anti-clockwise until tight. Then clockwise slightly to allow clearance. While holding dials in position lock in place by screwing down the Socket head Cap screws in the middle of each Cam (5mm allen key supplied with machine)
3. Pull saw back and forth along rail ensuring it slides smoothly.
4. Future adjustment may be needed depending on use of saw.

### Splinter Protection

The guide rail comes with a splinter guard, which must be fitted before the first use.

- 1 Secure rail with the screw clamps to a piece of scrap lumber.
- 2 Adjust the guide clearance on the rail with the two adjustment screws (E).
- 3 Set the plunge saw to ca. 6mm cut depth
- 4 Set up the saw at the back end of the rail.
- 5 Switch on the machine, press down to the set cut depth and fit the splinter guard along the whole length in one pass without stopping.

The edge of the splinter guard now corresponds exactly to the cutting edge of the saw blade

### Caution!

Always secure the workpiece in such a way that it cannot shift.

Always move the machine forward; never pull it toward the body.

## TO SAW:

- 1 Set the saw on the guide rail.
- 2 Switch on the machine.
- 3 Press the saw slowly down to the set cut depth and move this evenly forward along the rail.

## PLUNGE CUTS:

### To Saw:

- 1 Set the saw on the guide rail at the marked cutting point
- 2 Secure the rebound protection or fence (accessory not included) at the back and front cut points on the guide rail.
- 3 Switch on the machine.
- 4 Press the saw down slowly to the set cut depth and move this forward evenly on the rail up to the front cutting point.

### Tilt Protection:

For mitre cuts, it is advisable to install a tilt protection (accessory not included). This prevents the machine from tilting to one side while in an oblique position.

Injuries to the body or damage to the machine can be avoided thereby.



Plunge Saw

# Warranty Details

---

The product is guaranteed to be free from defects in workmanship and parts for a period of 36 months from the date of purchase. Defects that occur within this warranty period, under normal use and care, will be repaired, replaced or refunded at our discretion. The benefits conferred by this warranty are in addition to all rights and remedies in respect of the product that the consumer has under the Competition and Consumer Act 2010 and similar state and territory laws.

Our goods come with guarantees that cannot be excluded under the Australian Consumer Law. You are entitled to a replacement or refund for a major failure and for compensation for any other reasonably foreseeable loss or damage. You are also entitled to have the goods repaired or replaced if the goods fail to be of acceptable quality and the failure does not amount to a major failure.

---

**After Sales Support**

Telephone: 1300 130 579  
Internet: [www.support@schepach.com.au](http://www.support@schepach.com.au)





Plunge Saw

# Repair and Refurbished Goods or Parts Notice

---

Unfortunately, from time to time, faulty products are manufactured which need to be returned to the Supplier for repair.

Please be aware that if your product is capable of retaining user-generated data (such as files stored on a computer hard drive, telephone numbers stored on a mobile telephone, songs stored on a portable media player, games saved on a games console or files stored on a USB memory stick) during the process of repair, some or all of your stored data may be lost. **We recommend you save this data elsewhere prior to sending the product for repair.**

You should also be aware that rather than repairing goods, we may replace them with refurbished goods of the same type or use refurbished parts in the repair process.

**Please be assured though, refurbished parts or replacements are only used where they meet ALDI's stringent quality specifications.**

If at any time you feel your repair is being handled unsatisfactorily, you may escalate your complaint. Please telephone us on SUPPLIERTELEPHONE or write to us at:

SUPPLIER NAME	RossMac Pty. Ltd.
SUPPLIER ADDRESS	P.O. Box 261, Essendon North, Victoria, 3041
SUPPLIER TELEPHONE	1300 130 579
SUPPLIER EMAIL ADDRESS	<a href="http://www.support@schepach.com.au">www.support@schepach.com.au</a>

---

#### After Sales Support

Telephone: 1300 130 579  
Internet: [www.support@schepach.com.au](http://www.support@schepach.com.au)

