



# User Manual

## Contents

- Overview.....04
- Utilisation .....05
- Pack contents/parts .....06
- Explanation of symbols .....09
- Introduction .....10
- Layout .....11
- Scope of delivery .....12
- Intended use .....13
- Safety regulations .....14
- Before starting the equipment .....19
- Attachment .....19
- Operation .....24
- Working instructions .....24
- Technical data .....27
- Transport .....28
- Cleaning and maintenance .....28
- Storage .....29
- Electrical connection .....29
- Disposal and recycling .....30
- Troubleshooting .....31
- Warranty details .....33
- Repair and refurbished goods or parts notice.....34



## BANDSAW HBS20



Vers.No. 1712220

Original operating manual

ALDI guarantees that our exclusive brand products are developed to our stringent quality specifications. If you are not entirely satisfied with this product, please return it to the nearest ALDI store within 60 days from the date of purchase, for a full refund or replacement, or take advantage of our after sales support by calling the supplier's Customer Service Hotline.



### Made in China

WORKZONE® is a registered trademark of ALDI Stores

DISTRIBUTED BY:

ALDI STORES

1 SARGENTS ROAD

MINCHINBURY NSW 2770

www.aldi.com.au

### AFTER SALES SUPPORT

60339



AUS 1300 855 831

support@scheppach.com.au

MODEL:

HBS20

04/2018

# 5

YEARS  
WARRANTY

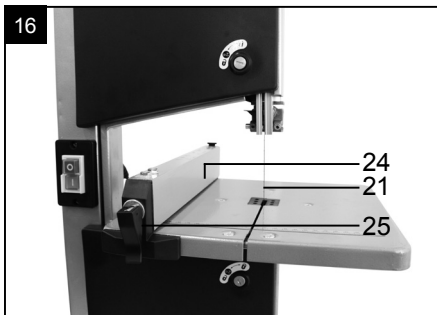
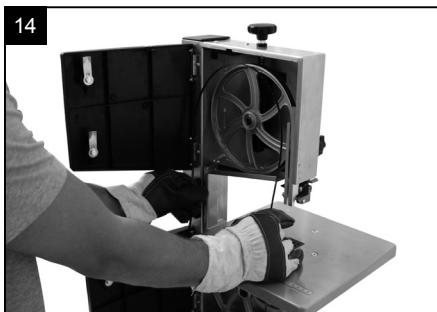
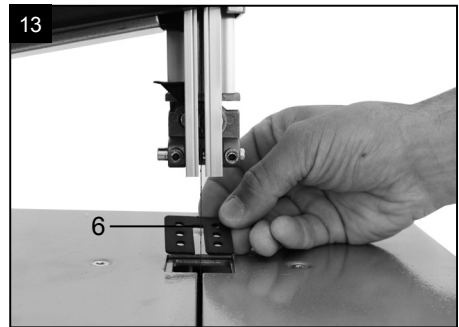
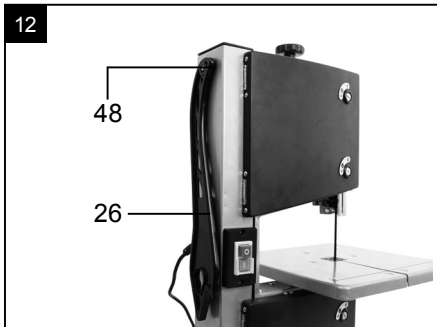
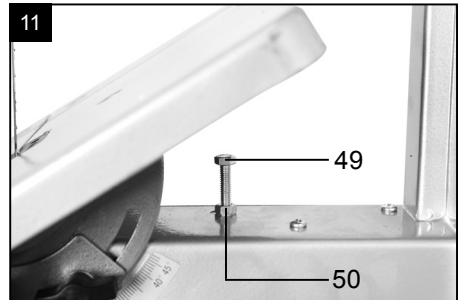
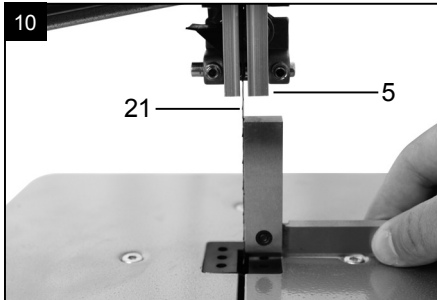

**AFTER SALES SUPPORT**

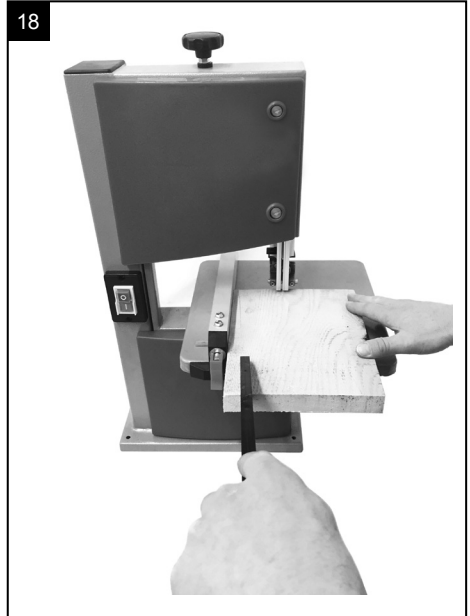

## Explanation of Symbols

	<p>Caution - Read the operating instructions to reduce the risk of injury!</p>
	<p>Wear ear-muffs. The impact of noise can cause damage to hearing.</p>
	<p>Wear a breathing mask. Dust which is injurious to health can be generated when working on wood and other materials.</p>
	<p>Wear safety goggles. Sparks generated during working or splinters, chips and dust emitted by the device can cause loss of sight.</p>
	<p>Wear protective gloves.</p>
	<p><b>Attention!</b> Before installation, cleaning, alterations, maintenance, storage and transport switch off the device and disconnect it from the power supply.</p>
	<p><b>Attention!</b> Observe the direction of rotation.</p>
	<p>Cover locking mechanism</p>

## I. Introduction

Congratulations on choosing to buy a WORKZONE® product.

All products brought to you by WORKZONE® are manufactured to the highest standards of performance and safety, and as part of our philosophy of customer service and satisfaction, are backed by our comprehensive 5 Year Warranty.

We hope you will enjoy using your purchase for many years to come.

### Note:

According to the applicable product liability law the manufacturer of this device is not liable for damages which arise on or in connection with this device in case of:

- improper handling,
- non-compliance with the instructions for use,
- repairs by third party, non-authorised skilled workers,
- installation and replacement of non-original spare parts,
- improper use,
- failures of the electrical system due to the non-compliance with the electrical specifications and regulations.

### Recommendations:

Read the entire text of the operating instructions prior to the assembly and operation of the device.

These operating instructions are intended to make it easier for you to get familiar with your device and utilise its intended possibilities of use.

The operating instructions contain important notes on how to work safely, properly and economically with your machine and how to avoid dangers, save repair costs, reduce downtime, and increase the reliability and working life of the machine.

In addition to the safety regulations contained herein, you must in any case comply with the applicable regulations of your country with respect to the operation of the machine.

Put the operating instructions in a clear plastic folder to protect them from dirt and humidity, and store them near the machine. The instructions must be read and carefully observed by each operator prior to starting the work. Only persons who have been trained in the use of the machine and have been informed on the related dangers and risks are allowed to use the machine. The required minimum age must be met.

In addition to the safety notes contained in the present operating instructions and the special regulations of your country, the generally recognised technical rules for the operation of identically constructed machines must be observed.

## II. Layout (Fig. 1-16)

1. Clamping screw
2. Top saw band roller
3. Rubber surface
4. Saw band guard
5. Top saw band guide
6. Table insert
7. Saw table
8. Bottom saw band roller
9. Foot
10. Cover locking mechanism
11. Side cover
12. On/off switch
13. Locking screw for top saw band roller
14. Set screw for top saw band roller
15. Machine frame
16. Mains cable
17. Degree scale for swivel range
18. Motor
19. Extraction nozzle
20. Locking handle for saw table
21. Saw band
22. Adjustment handle for saw band guide
23. Locking handle for saw band guide
24. Parallel stop
25. Clamping bar for parallel stop
26. Push stick
27. 3 mm Allen key
28. 4 mm Allen key
29. Screwdriver
30. Open-ended spanner
31. Wing nut
32. Clamping plate
33. Knurled nut
34. U-reinforcement
35. Allen screw for top support bearing
36. Top support bearing
37. Top guide pin

38. Allen screw for top guide pins
39. Retainer (top)
40. Allen screw for top retainer (2x)
41. Allen screw for bottom support bearing
42. Bottom support bearing
43. Screw for bottom retainer
44. Saw band protection
45. Allen screw for bottom guide pins
46. Bottom guide pin
47. Retainer (bottom)
48. Push stick retainer
49. Screw (saw table adjustment)
50. Nut (saw table adjustment)

### III. Scope of delivery

- Bandsaw
  - Saw table
  - Push stick
  - Parallel stop
  - Open-ended spanner, size 10/13
  - Allen key, size 3/4
  - Screwdriver
  - Instruction manual
  - Warranty card
- 
- Open the packaging and remove the device carefully.
  - Remove the packaging material as well as the packaging and transport bracing (if available).
  - Check that the delivery is complete.
  - Check the device and accessory parts for transport damage.
  - If possible, store the packaging until the warranty period has expired.

#### **⚠ ATTENTION!**

**The device and packaging materials are not toys!**

**Children must not be allowed to play with plastic bags, film and small parts!**

**There is a risk of swallowing and suffocation!**

## IV. Intended use

The bandsaw is designed to perform longitudinal and cross cuts on timber or wood-type materials. To cut round materials you must use suitable holding devices.

The machine is to be used only for its prescribed purpose. This machine is for domestic DIY use only. Any other use is deemed to be a case of misuse. The user / operator and not the manufacturer will be liable for any damage or injuries of any kind caused as a result of this.

The machine is to be operated only with suitable saw blades. To use the machine properly you must also observe the safety regulations, the assembly instructions and the operating instructions to be found in this manual.

All persons who use and service the machine have to be acquainted with this manual and must be informed about the machine's potential hazards.

It is also imperative to observe the accident prevention regulations in force in your area. The same applies for the general rules of occupational health and safety.

The manufacturer shall not be liable for any changes made to the machine nor for any damage resulting from such changes.

Even when the machine is used as prescribed it is still impossible to eliminate certain residual risk factors. The following hazards may arise in connection with the machine's construction and design:

- Damage to hearing if ear-muffs are not used as necessary.
- Harmful emissions of wood dust when used in closed rooms.
- Contact with the blade in the uncovered cutting zone.
- Injuries (cuts) when changing the blade.
- Injury from catapulted workpieces or parts of workpieces.
- Crushed fingers.
- Kickback.
- Tilting of the workpiece due to inadequate support.
- Touching the blade.
- Catapulting of pieces of timber and workpieces.

Please note that our machine has not been designed for use in commercial, trade or industrial applications. Our warranty will be voided if the machine is used in commercial, trade or industrial businesses or for equivalent purposes.



## V. Safety regulations

**ATTENTION!** The following basic safety measures must be observed when using electric tools for protection against electric shock, and the risk of injury and fire. Read all these notices before using the electric tool and keep the safety instructions for later reference.

### Safe work

#### 1 Keep the work area orderly

- Disorder in the work area can lead to accidents.

#### 2 Take environmental influences into account

- Do not expose electric tools to rain.
- Do not use electric tools in a damp or wet environment.
- Make sure that the work area is well-illuminated.
- Do not use electric tools where there is a risk of fire or explosion.

#### 3 Protect yourself from electric shock

- Avoid physical contact with earthed parts (e.g. pipes, radiators, electric ranges, cooling units).

#### 4 Keep children away

- Do not allow other persons to touch the equipment or cable, keep them away from your work area.

#### 5 Securely store unused electric tools

- Unused electric tools should be stored in a dry, elevated or closed location out of the reach of children.

#### 6 Do not overload your electric tool

- They work better and more safely in the specified output range.

#### 7 Use the correct electric tool

- Do not use low-output electric tools for heavy work.
- Do not use the electric tool for purposes for which it is not intended.
- Do not use bandsaw to cut firewood, food and meat.

#### 8 Wear suitable clothing

- Do not wear wide clothing or jewellery, which can become entangled in moving parts.
- When working outdoors, anti-slip footwear is recommended.
- Tie long hair back in a hair net.

#### 9 Use protective equipment

- Wear protective goggles.
- Wear a mask when carrying out dust-creating work.

#### 10 Connect the dust extraction device if you will be processing wood, mate-

**Materials similar to wood, or plastics.**

- If connections for dust extraction and a collecting device are present, make sure that they are connected and used properly.
- When processing wood, materials similar to wood, and plastics. operation in enclosed spaces is only permitted with the use of a suitable extraction system.

**11 Secure the workpiece**

- Use the clamping devices or a vice to hold the workpiece in place. In this manner, it is held more securely than with your hand.
- An additional support is necessary for long workpieces (table, trestle, etc.) in order to prevent the machine from tipping over.
- Always press the workpiece firmly against the working plate and stop in order to prevent bouncing and twisting of the workpiece.

**12 Avoid abnormal posture**

- Make sure that you have secure footing and always maintain your balance.
- Avoid awkward hand positions in which a sudden slip could cause one or both hands to come into contact with the saw blade.

**13 Take care of your tools**

- Keep cutting tools sharp and clean in order to be able to work better and more safely.
- Follow the instructions for lubrication and for tool replacement.
- Check the connection cable of the electric tool regularly and have it replaced by a recognised specialist when damaged.
- Check extension cables regularly and replace them when damaged.
- Keep the control panel and micro switch dry, clean and free of oil and grease.

**14 Pull the plug out of the outlet**

- Never remove loose splinters, chips or jammed wood pieces from the running saw blade.
- During non-use of the electric tool or prior to maintenance and when replacing tools such as saw blades, bits, milling heads.
- When the saw blade is blocked due to abnormal feed force during cutting, turn the machine off and disconnect it from power supply. Remove the work piece and ensure that the saw blade runs free. Turn the machine on and start new cutting operation with reduced feed force.

**15 Do not leave a tool key inserted**

- Before switching on, make sure that keys and adjusting tools are removed.

**16 Avoid inadvertent starting**

- Make sure that the switch is switched off when plugging the plug into an outlet.

**17 Use extension cables for outdoors**

- Only use approved and appropriately identified extension cables for use outdoors.
- Only use cable reels in the unrolled state.

### **18 Remain attentive**

- Pay attention to what you are doing. Remain sensible when working. Do not use the electric tool when you are distracted.

### **19 Check the electric tool for potential damage**

- Protective devices and other parts must be carefully inspected to ensure that they are fault-free and function as intended prior to continued use of the electric tool.
- Check whether the moving parts function faultlessly and do not jam or whether parts are damaged. All parts must be correctly mounted and all conditions must be fulfilled to ensure fault-free operation of the electric tool.
- The moving protective hood may not be fixed in the open position.
- Damaged protective devices and parts must be properly repaired or replaced by a recognised workshop, insofar as nothing different is specified in the operating manual.
- Damaged switches must be replaced at a customer service workshop.
- Do not use any faulty or damaged connection cables.
- Do not use any electric tool on which the switch cannot be switched on and off.

### **20 ATTENTION!**

- The use of other insertion tools and other accessories can entail a risk of injury.

### **21 Have your electric tool repaired by a qualified electrician**

- This electric tool conforms to the applicable safety regulations. Repairs may only be performed by an electrician using original spare parts. Otherwise accidents can occur.

### **22 Do not use the cable for purposes for which it is not intended.**

- Do not use the cable to pull the plug out of the outlet.
- Protect the cable from heat, oil and sharp edges.

### **Additional safety instructions**

- Wear safety gloves whenever you carry out any maintenance work on the blade!
- When cutting round or irregularly shaped wood, use a device to stop the workpiece from twisting.
- When cutting boards in upright position, use a device to prevent kick-back.
- A dust extraction system designed for an air velocity of 20 m/s should be connected in order to comply with woodworking dust emission values and to ensure reliable operation.

- Give these safety regulations to all persons who work on the machine.
- Do not use this saw to cut fire wood.
- The machine is equipped with a safety switch to prevent it being switched on again accidentally after a power failure.
- Before you use the machine for the first time, check that the voltage marked on the rating plate is the same as your mains voltage.
- If you use a cable reel, the complete cable has to be pulled off the reel.
- Persons working on the machine should not be distracted.
- Note the direction of rotation of the motor and blade.
- Never dismantle the machine's safety devices or put them out of operation.
- Never cut workpieces which are too small to hold securely in your hand.
- Never remove loose splinters, chips or jammed pieces of wood when the saw blade is running.
- It is imperative to observe the accident prevention regulations in force in your area as well as all other generally recognized rules of safety.
- Note the information published by your professional associations.
- Adjustable protective devices have to be adjusted as close as possible to the workpiece.
- Important! Support long workpieces (e.g. with a roller table) to prevent them sagging at the end of a cut.
- Make sure the saw band guard (4) is in its lower position when the saw is being transported.
- Safety guards are not to be used to move or misuse the machine.
- Blades that are misshapen or damaged in any way must not be used.
- If the table insert is worn, replace it.
- Never operate the machine if either the door protecting the blade or the detachable safety device are open.
- Ensure that the choice of blade and the selected speed are suitable for the material to be cut.
- Do not begin cleaning the blade until it has come to a complete standstill.
- For straight cuts of small workpieces against the longitudinal limit stop the push stick has to be used.
- The saw band guard should be in its lowest position close to the bench during transport.
- For miter cuts when the table is tilted, the parallel stop must be positioned on the lower part of the table.
- When cutting round timber, use a suitable holding device to prevent the workpiece turning.

---

## AFTER SALES SUPPORT

17

- Never use guards to lift or transport items.
- Ensure that the saw band guards are used and correctly adjusted.
- Keep your hands a safety distance away from the bandsaw blade. Use a push stick for narrow cuts.
- The push stick has to be stored on the intended device, so that it can be reached from normal working position and is always ready to be used.
- In the normal operating position the operator is in front of the machine.

### Residual risks

The machine has been built using modern technology in accordance with recognized safety rules. Some remaining hazards, however, may still exist.

- Risk of injury for fingers and hands by the rotating saw band due to improper handling of the work piece.
- Risk of injury through the hurling work piece due to improper handling, such as working without the push stick.
- Risk of damaging your health due to wood dust and wood chips. Wear personal protective cloth such as goggles. Use a fitting dust extractor.
- Risk of injury due to defective saw band. Regularly check saw band for such defects.
- Risk of injury for fingers and hands while changing saw band. Wear proper gloves.
- Risk of injury due to starting saw band while switching on the machine.
- The use of incorrect or damaged mains cables can lead to injuries caused by electricity.
- Wear only closefitting clothes. Remove rings, bracelets and other jewellery.
- For the safety of long hair, wear a cap or hair net. Even when all safety measures are taken, some remaining hazards which are not yet evident may still be present.
- Remaining hazards can be minimized by following the instructions in "Safety regulations" and in the entire operating manual.

## VI. Before starting the equipment

Make sure the machine stands securely, i.e. bolt it to a workbench or solid base. There are four holes for this purpose in the machine foot.

- The saw table must be mounted correctly.
- All covers and safety devices have to be properly fitted before the machine is switched on.
- It must be possible for the blade to run freely.
- When working with wood that has been processed before, watch out for foreign bodies such as nails or screws etc.
- Before you actuate the On/Off switch, make sure that the saw blade is correctly fitted and that the machine's moving parts run smoothly.
- Before you connect the machine to the power supply, make sure the data on the rating plate is the same as that for your mains.

## VII. Attachment

### ATTENTION!

Before all maintenance, set-up and assembly work on the bandsaw, unplug the mains plug.

### Assembly tools

- 1 Open-ended spanner, size 10/13
- 1 Allen key, size 3
- 1 Allen key, size 4
- 1 Screwdriver

The saw table is not assembled for packaging reasons.

### Assembling the saw table (Fig. 2-4)

- Remove the wing nut (31), the locking handle for saw blade (20), the two washers and the clamping plate (32). (Fig.2)
- Remove the two knurled nuts (33), the U-reinforcement (34) and the two counter-sunk screws M6x16 from the saw table. (Fig. 3)
- Guide the saw table (7) over the saw band (21). Fasten it to the two screws on the machine frame with the clamping plate (32), the two washers, the wing nut (31) and the locking handle for saw blade (20). (Fig. 4)
- Fasten the U-reinforcement (34) to the front side of the saw table with 2 counter-sunk screws M6x16 and 2 knurled nuts (33). (Fig.3)

### Tensioning the saw band (Fig. 1a)

- **ATTENTION!** If the saw is at a standstill for an extended period the saw band tension must be relieved, i.e. before switching the saw on it is necessary to check the saw blade tension.
- Turn the clamping screw (1) clockwise to tension the saw band (21). The correct tension of the saw band can be determined by pressing the finger laterally against the saw band, roughly centrally between the two saw band rollers (2+8). The saw band (21) should only depress slightly (approx. 1-2 mm) here.
- The sufficiently tensioned saw band makes a metallic sound when tapped.
- Relieve the saw band tension if it is not in use for an extended time, so that it does not become overstretched.
- **ATTENTION!** With high tension, the saw band may break. **RISK OF INJURY!** If the tension is too low, the bottom saw band roller (8) may spin, resulting in the saw band coming to a standstill.

### Adjusting the saw band (Fig. 1a+1b)

- **ATTENTION!** Before it is possible to implement the saw band setting, the saw band must be tensioned correctly.
- Open the side covers (11) by undoing the cover locking mechanisms (10) with the help of the screwdriver (29).
- Slowly turn the top saw band roller (2) clockwise. The saw band (21) should run centrally on the top saw band roller (2). If this is not the case, the angle of the top saw band roller (2) must be corrected.
- If the saw band (21) runs more towards the rear edge of the top saw band roller (2) then the set screw for top saw band roller (14) must be rotated anticlockwise.
- Open the locking screw for top saw band roller (13).
- Turn the bottom saw band roller (8) slowly by hand, to check the position of the saw band (21).
- If the saw band (21) runs more towards the front edge of the top saw band roller (2) then the set screw for top saw band roller (14) must be rotated clockwise.
- After setting the top saw band roller (2), check the position of the saw band (21) on the bottom saw band roller (8). The saw band (21) should also lie centrally on the bottom saw band roller (8) here. If this is not the case, the angle of the top saw band roller (2) must be adjusted again.
- Turn the saw band roller a few times, until the adjustment of the top saw band roller (2) acts on the saw band position on the bottom saw band roller (8).
- Tighten the locking screw for top saw band roller (13).
- Once adjustment is complete, close the side covers (11) again and secure with the

cover locking mechanisms (10) with the help of the screwdriver (29).

### **Adjusting the saw band guide (Fig. 5 - 8)**

- Both the support bearing (36 + 42) and the guide pins (37 + 46) must be readjusted after every saw band change.
- Open the side covers (11) by undoing the cover locking mechanisms (10) with the help of the screwdriver (29).

### **Top support bearing (36) (Fig.5)**

- Undo Allen screw for top support bearing (35).
- Move top support bearing (36) sufficiently far that it just no longer touches the saw band (21) (distance max. 0.5 mm).
- Retighten the allen screw for top support bearing (35).

### **Adjusting the bottom support bearing (42)**

- Disassemble the saw table.
- Undo Allen screw for bottom support bearing (41).
- Move bottom support bearing (42) sufficiently far that it just no longer touches the saw band (21) (distance max. 0.5 mm).
- Retighten Allen screw for bottom support bearing (41).

### **Adjusting the top guide pins (37)**

- Undo Allen screw for top retainer (40).
- Move top retainer (39), top guide pins (37), until the front edge of the top guide pins (37) is approx. 1 mm behind the tooth base of the saw band.
- Retighten Allen screw for top retainer (40).
- **ATTENTION!** The saw band will be unusable if the teeth touch the guide pins with the saw band running.
- Undo Allen screws for top guide pins (38).
- Slide the top guide pins (37) in the direction of the saw band!
- **ATTENTION!** The distance between the top guide pins (37) and saw band (21) must not exceed 0.5 mm. (Saw band must not jam)
- Retighten Allen screws (38).
- Turn the top saw band roller (2) a few times in a clockwise direction.
- Check the setting of the top guide pins (37) again and adjust if necessary.
- If necessary, adjust the top support bearing (36).



**Adjusting the bottom guide pins (46) (Fig.7+8)**

- Disassemble saw table (7).
- Undo screw for bottom retainer (43).
- Move bottom retainer (47), bottom guide pins (46), until the front edge of the bottom guide pins (46) is approx. 1 mm behind the tooth base of the saw band.
- Retighten screw for bottom retainer (43).
- **ATTENTION!** The saw band will be unusable if the teeth touch the guide pins with the saw band running.
- Undo Allen screws for bottom guide pins (45).
- Slide the two bottom guide pins (46) sufficiently far in the direction of the saw band that the distance between the bottom guide pins (46) and saw band (21) is max. 0.5 mm. (Saw band must not jam)
- Retighten Allen screws for bottom guide pins (45).
- Turn the bottom saw band roller (8) a few times in a clockwise direction.
- Check the setting of the bottom guide pins (46) again and adjust if necessary.
- If necessary, adjust the bottom support bearing (42).

**Adjusting the top saw band guide (5) (Fig. 9)**

- Undo locking handle for saw band guide (23).
- Turn the adjustment handle for the saw band guide (22) to lower the top saw band guide (5) as closely as possible (distance approx. 2-3 mm) over the material to be cut.
- Retighten locking handle for saw band guide (23).
- Check the setting before every cutting process and adjust if necessary.

**Adjusting the saw table (7) to 90° (Fig.10+11)**

- Set the top saw band guide (5) fully upwards.
- Undo locking handle for saw band table (20) and wing nut (31).
- Place the angle bracket between the saw band (21) and saw table (7). Angle bracket not included in the scope of supply.
- Tilt the saw table (7) by turning, until the angle to the saw band (21) is precisely 90°. If the saw table is already on the screw (49) and a 90° angle cannot be set, undo the nut (50) and shorten the screw (49) by turning in a clockwise direction.
- Retighten the locking handle for saw band guide (20) and wing nut (31).
- Also undo the nut (50).
- Adjust the screw (49) sufficiently that the saw table touches the underside.
- Retighten the nut (50) to fix the screw (49) in position.

**Which saw band to use**

- The saw band supplied in the bandsaw is intended for universal use. The following criteria should be considered when selecting the saw band:
- It is possible to cut tighter radii with a narrow saw band than with a wide saw band.
- A wide saw band is used if a straight cut is required. This is important in particular when cutting wood. The saw band has a tendency to follow the wood grain and therefore deviates easily from the desired cutting line.
- Fine-toothed saw bands cut more smoothly, but also more slowly than coarse saw bands.
- **ATTENTION!** Never use bent or torn saw bands!

**Replacing the saw band (Fig. 1a+1b+14)**

- Set the top saw band guide (5) at approx. half height between the saw table (7) and machine frame (15).
- Undo the cover locking mechanisms (10) and open the side covers (11).
- Remove the U-reinforcement (34).
- Relieve the saw band (21) tension by turning the clamping screw (1) anti-clockwise.
- Remove the saw band (21) from the saw band rollers (2+8) and through the slot in the saw table (7).
- Place the new saw band (21) centrally on both saw band rollers (2+8). The teeth of the saw band (21) must point downwards in the direction of the saw table.
- Tension the saw band (21).
- Close the side cover (11) again.
- Re-install the U-reinforcement (34).

**Replacing the table insert (Fig. 13)**

- In case of wear or damage, the table insert (6) must be replaced; otherwise there is an increased risk of injury.
- Remove the worn table insert (6) by lifting it up and out.
- Installation of the new table insert takes place in reverse order.

**Extraction nozzle (Fig. 1b)**

- The bandsaw is equipped with an extraction nozzle (19) Ø 40mm for chips.
- Only operate the device with a suitable extraction system. Check and clean the suction channels at regular intervals.

**Push rod retainer (Fig. 12)**

- The push stick retainer (48) is pre-mounted on the machine frame. If unused, the push stick (26) must always be stowed in the push stick retainer.

---

**AFTER SALES SUPPORT**

## VIII. Operation

### On/Off switch (12)(Fig. 15)

- To turn the machine on, press the green button “1”.
- To turn the machine off again, press the red button “0”.
- The bandsaw is equipped with an undervoltage switch. With a power failure, the bandsaw must be switched back on again.

### Parallel stop (Fig. 16)

- Press the clamping bar (25) for the parallel stop (24) upwards.
- Slide the parallel stop (24) left or right of the saw band (21) on the saw table (7) and set to the desired measurement.
- Press the clamping bar for parallel stop (25) down to fix the parallel stop (24) in place. In order to increase the clamping force of the clamping bar for parallel stop (25), rotate it clockwise until the parallel stop is sufficiently fixed in place.
- Make sure that the parallel stop (24) always runs parallel to the saw band (21).

### Angled cuts (Fig. 17)

- In order to execute angled cuts parallel to the saw band (21), it is possible to tilt the saw table (7) forwards from 0° - 45°.
- Undo locking handle (20) and wing nut (31).
- Tilt saw table (7) forwards, until the desired angle is set on the degree scale for swivel range (17).
- Retighten the locking handle for saw table (20) and wing nut (31).
- **ATTENTION!** With a tilted saw table (7), the parallel stop (24) must always be fitted to the right of the saw band (21) in the working direction. This prevents the workpiece from slipping.

## IX. Working instructions

The following recommendations are examples of the safe use of bandsaws. The following safe working methods should be seen as an aid to safety. They cannot be applied suitably completely or comprehensively to every use. They cannot treat every possible dangerous condition and must be interpreted carefully.

- Connect the machine to a suction unit when working in closed rooms. A suction device which conforms with commercial regulations must be used for suction in commercial areas.
- Loosen the saw band when the machine is not in operation (e.g. after finishing work). Attach a notice on the tension of the saw band to the machine for the next

user.

- Collect unused saw bands and store them safely in a dry place. Check for faults (teeth, cracks) before use. Do not use faulty saw bands!
- Wear suitable gloves when handling saw bands.
- All protective and safety devices must be securely mounted on the machine before beginning work.
- Never clean the saw band or the saw band guide with a hand-held brush or scraper while the saw band is running. Resin-covered saw bands impair working safety and must be cleaned regularly.
- For your own protection, wear protective glasses and hearing protection. Wear a hairnet if you have long hair. Roll up loose sleeves over the elbows.
- Always position the saw band guide as near the workpiece as possible when working.
- Ensure sufficient lighting in the work area and around the machine.
- Always use the fence for straight cuts to keep the workpiece from tipping or slipping away.
- When working on narrow workpieces with manual feed, use the push stick.
- For diagonal cuts, place the saw table in the appropriate position and guide the workpiece on the fence.
- In order to cut dovetail tenons and teeth or wedges, bring the saw table into the corresponding position on the angle scale.
- For arced and irregular cuts, push the workpiece evenly using both hands with the fingers together. Hold the workpiece with your hands on a safe area.
- Use a pattern for repeated arced or irregular cuts.
- Ensure that the workpiece does not roll when cutting round pieces.

**ATTENTION!** After every new setting, we recommend performing a test cut, in order to check the dimensional settings.

- With all cutting processes, the top saw band guide (5) must be positioned as close as possible to the workpiece.
- The workpiece must always be guided with both hands and kept flat against the saw table (7). This prevents the saw band (21) from jamming.
- Forward feeding should always take place with an even pressure, which is just sufficient for the saw band to cut through the material with ease without becoming blocked.
- Always use the parallel stop (24) for all cutting processes that it can be used for.
- It is better to perform a cut in a single working step than in multiple steps, which may require that the workpiece be drawn back. However, if it is not possible to avoid drawing the workpiece back then the bandsaw must be switched off first.

Only draw the workpiece back once the saw band (21) has come to a standstill.

- When sawing, the workpiece must always be guided by its longest side.
- **ATTENTION!** When processing narrower workpieces it is essential to use a push stick. The push stick (26) must always be stored within reach, on the push stick retainer (48) provided for this purpose on the side of the saw.

### Performing longitudinal cuts (Fig. 18)

Here, a workpiece is cut in its longitudinal direction.

- Position the parallel stop (24) on the left side (if possible) of the saw band (21), in accordance with the desired width.
- Lower the top saw guide (5) onto the workpiece.
- Switch on the saw.
- Press one edge of the workpiece against the parallel stop (24) with the right hand, whilst the flat side lies on the saw table (7).
- Slide the workpiece at an even feed rate along the parallel stop (24) into the saw band (21).
- **Important:** Long workpieces must be secured against tipping at the end of the cutting process (e.g. with reel-off stand, etc.)

### Performing angled cuts (Fig. 17)

- Set saw table to desired angle (see “Angled cuts”).
- Perform the cut as described under “Performing longitudinal cuts”.

When producing angled cuts, only use the parallel stop to the right of the saw band.

### Freehand cuts (Fig. 19)

One of the most important features of a bandsaw is the ease with which it can cut curves and radii.

- Lower the top saw band guide (5) onto the workpiece.
- Switch on the saw.
- Press the workpiece firmly onto the saw table (7) and slowly slide into the saw band (21).
- In many cases it is helpful to roughly saw curves and corners approximately 6 mm from the line.
- If it is necessary to saw curves that are too tight for the saw band used, auxiliary cuts must be sawn up to the front face of the curve, so that these fall off as wood waste when the final radius is sawn.

## X. Technical data

<b>AC motor</b>	230-240 V~ 50 Hz
<b>Power</b>	S1 250 W / S2 30 min 350 W
<b>Revolutions <math>n_0</math></b>	1400 min <sup>-1</sup>
<b>Saw band length</b>	1400 mm
<b>Saw band width</b>	3.5 - 12 mm
<b>Saw band width max.</b>	12 mm
<b>Saw band thickness (recommended)</b>	0.35 mm
<b>Cutting speed</b>	900 m/min
<b>Passage height</b>	0 - 80 mm
<b>Passage width</b>	200 mm
<b>Table size</b>	300 x 300 mm
<b>Slewing range of the table</b>	0° - 45°
<b>Max. size of the workpiece</b>	400 x 400 x 80 mm
<b>Overall weight approx.</b>	16.2 kg

\* Operating mode S1, continuous operation.

\* Operating mode S2, short-term operation with constant load; Duration of nominal operation

The work piece must have a minimum height of 3mm and a minimum width of 10 mm.

Noise parameters

The total noise values determined in accordance with EN 61029.

<b>sound pressure level <math>L_{pA}</math></b>	77.4 dB(A)
<b>uncertainty <math>K_{pA}</math></b>	3 dB
<b>sound power level <math>L_{WA}</math></b>	90.4 dB(A)
<b>uncertainty <math>K_{WA}</math></b>	3 dB

**Wear hearing protection.**

The effects of noise can cause a loss of hearing. Keep the noise level and vibration to a minimum!

- Only use faultless devices.
- Maintain and clean the device at regular intervals.
- Adapt your working methods to the device.
- Do not overload the device.
- Have the device checked if necessary.
- Switch the device off if it is not in use.

**XI. Transport**

The machine must only be lifted and transported on its frame or the frame plate. Never lift the machine at the safety devices, the adjusting levers, or the saw table. During the transport the saw band protection must be in the lowest position and near the table.

Never raise at the table!

Unplug the machine from the mains during transport.

**XII. Cleaning and maintenance**

Warning! Prior to any adjustment, maintenance or service work disconnect the mains power plug!

**Cleaning**

- Keep all safety devices, air vents and the motor housing free of dirt and dust as far as possible. Wipe the equipment with a clean cloth or blow it with compressed air at low pressure.
- We recommend that you clean the device immediately each time you have finished using it.

**Maintenance**

There are no parts inside the equipment which require additional maintenance.

### XIII. Storage

Store the device and its accessories in a dark, dry and frost-proof place that is inaccessible to children. The optimum storage temperature is between 5 and 30°C. Store the electrical tool in its original packaging.

Cover the electrical tool in order to protect it from dust and moisture.

Store the operating manual with the electrical tool.

### XIV. Electrical connection

**The electrical motor installed is connected and ready for operation. The connection complies with the applicable Australian standards. The customer's mains connection as well as the extension cable used must also comply with these regulations.**

#### Important information

In the event of an overloading the motor will switch itself off. After a cool-down period (time varies) the motor can be switched back on again.

#### Damaged electrical connection cable

The insulation on electrical connection cables is often damaged.

This may have the following causes:

- Passage points, where connection cables are passed through windows or doors.
- Kinks where the connection cable has been improperly fastened or routed.
- Places where the connection cables have been cut due to being driven over.
- Insulation damage due to being ripped out of the wall outlet.
- Cracks due to the insulation ageing.

Such damaged electrical connection cables must not be used and are life-threatening due to the insulation damage. Check the electrical connection cables for damage regularly. Make sure that the power is switched off before inspecting the cable. Electrical connection cables must comply with the applicable Australian standards and must be correctly marked. Only use connection cables with the marking "H05VV-F". Replacement cables can only be fitted by an approved and certified electrician. If you are in any doubt please contact the help line at the foot of this page.

#### AC motor

- The mains voltage must be 230 - 240 V~
- Extension cables up to 25 m long must have a cross-section of 1.5 mm<sup>2</sup>.

Connections and repairs of electrical equipment may only be carried out by an electrician.



Please provide the following information in the event of any enquiries:

- Type of current for the motor
- Machine data - type plate

## **XV. Disposal and recycling**

The equipment is supplied in packaging to prevent it from being damaged in transit. The raw materials in this packaging can be reused or recycled. The equipment and its accessories are made of various types of material, such as metal and plastic. Defective components must be disposed of as special waste. Ask your dealer or your local council.

## XVI. Troubleshooting

Fault	Possible cause	Remedy
Motor does not work.	Motor, cable or plug defective, fuses burnt  Housing cover open (limit switch)	Arrange for inspection of the machine by a specialist. Never repair the motor yourself. Danger! Check fuses and replace as necessary. Close housing cover exactly.
The motor starts up slowly and does not reach operating speed.	Voltage too low, coils damaged, capacitor burnt	Contact the utility provider to check the voltage. Arrange for inspection of the motor by a specialist. Arrange for replacement of the capacitor by a specialist.
Motor makes excessive noise.	Coils damaged, motor defective	Arrange for inspection of the motor by a specialist.
The motor does not reach its full power.	Circuits in the network are overloaded (lamps, other motors, etc.)	Do not use any other equipment or motors on the same circuit.
Motor overheats easily.	Overloading of the motor, insufficient cooling of the motor	Avoid overloading the motor while cutting, remove dust from the motor in order to ensure optimal cooling of the motor.
Saw cut is rough or wavy.	Saw blade dull, tooth shape not appropriate for the material thickness	Resharpener saw blade and/or use suitable saw blade.
Workpiece pulls away and/or splinters.	Excessive cutting pressure and/or saw blade not suitable for use	Insert suitable saw blade.
Saw blade is not running straight.	a) Guide has been wrongly set b) Wrong saw blade	a) Set the saw blade guide according to the operating instructions. b) Select a saw blade according to the operating instructions.
Burn marks appear on the wood during the cutting work.	a) Blunt saw blade b) Wrong saw blade	a) Change the saw blade. b) Select a saw blade according to the operating instructions.
Saw blade jams during cutting work.	a) Blunt saw blade. b) Deposits on the saw blade. c) Guide has been set poorly.	a) Change the saw blade. b) Clean the saw blade. c) Set the saw blade guide according to the operating instructions.



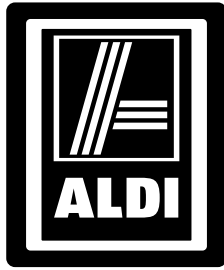

**WORKZONE®**

**BAND SAW**

## Warranty Details

---

REGISTER YOUR PURCHASE AT [www.aldi.com.au/en/about-aldi/product-registration/](http://www.aldi.com.au/en/about-aldi/product-registration/) TO KEEP UP-TO-DATE WITH IMPORTANT PRODUCT INFORMATION

---

The product is guaranteed to be free from defects in workmanship and parts for a period of 60 months from the date of purchase. Defects that occur within this warranty period, under normal use and care, will be repaired, replaced or refunded at our discretion. The benefits conferred by this warranty are in addition to all rights and remedies in respect of the product that the consumer has under the Competition and Consumer Act 2010 and similar state and territory laws.

Our goods come with guarantees that cannot be excluded under the Australian Consumer Law. You are entitled to a replacement or refund for a major failure and for compensation for any other reasonably foreseeable loss or damage. You are also entitled to have the goods repaired or replaced if the goods fail to be of acceptable quality and the failure does not amount to a major failure.

---

**AFTER SALES SUPPORT**

  **1300 855 831**

 [support@schepach.com.au](mailto:support@schepach.com.au)

MODEL: HBS20 PRODUCT CODE: 60339 04/2018

**5**  
YEARS  
WARRANTY



**WORKZONE®**

**BAND SAW**

# **Repair and Refurbished Goods or Parts Notice**

---

Unfortunately, from time to time, faulty products are manufactured which need to be returned to the Supplier for repair.

Please be aware that if your product is capable of retaining user-generated data (such as files stored on a computer hard drive, telephone numbers stored on a mobile telephone, songs stored on a portable media player, games saved on a games console or files stored on a USB memory stick) during the process of repair, some or all of your stored data may be lost.

**We recommend you save this data elsewhere prior to sending the product for repair.**

You should also be aware that rather than repairing goods, we may replace them with refurbished goods of the same type or use refurbished parts in the repair process.

**Please be assured though, refurbished parts or replacements are only used where they meet ALDI's stringent quality specifications.**

If at any time you feel your repair is being handled unsatisfactorily, you may escalate your complaint. Please telephone us on 1300 855 831 or write to us at:

**RossMac Pty. Ltd.**



**P.O. Box 261, Essendon North, Victoria, 3041**

**Telephone: 1300 855 831 (Monday - Friday 8:30am-6:00pm)**

**Email: [support@scheppach.com.au](mailto:support@scheppach.com.au)**

---

**AFTER SALES SUPPORT**

  **1300 855 831**

 [support@scheppach.com.au](mailto:support@scheppach.com.au)

MODEL: HBS20 PRODUCT CODE: 60339 04/2018

**5**  
YEARS  
WARRANTY

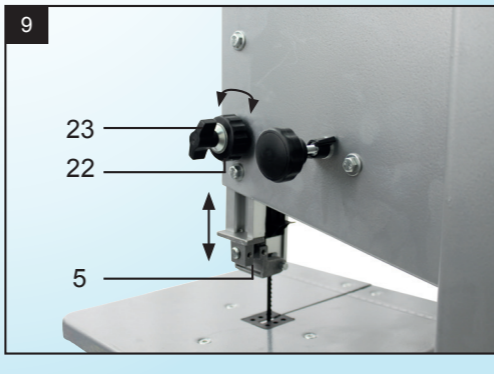
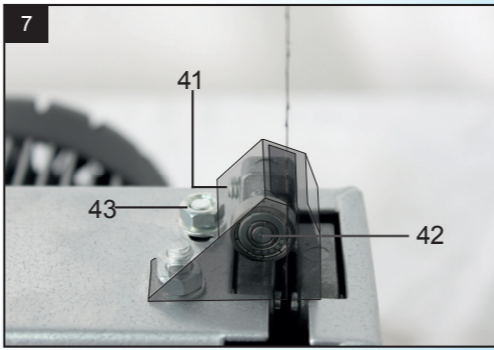
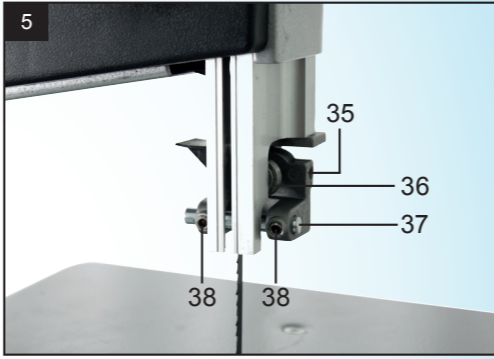
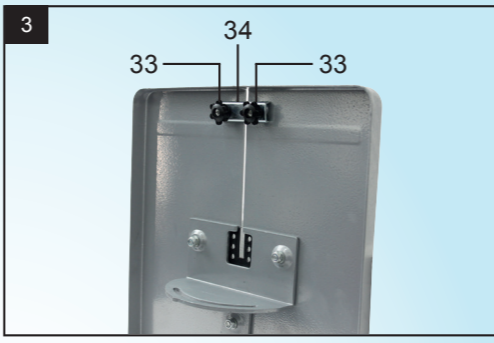
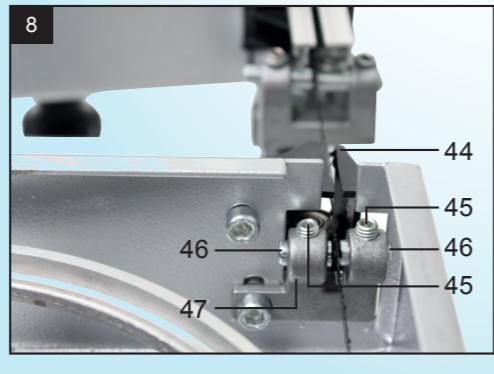
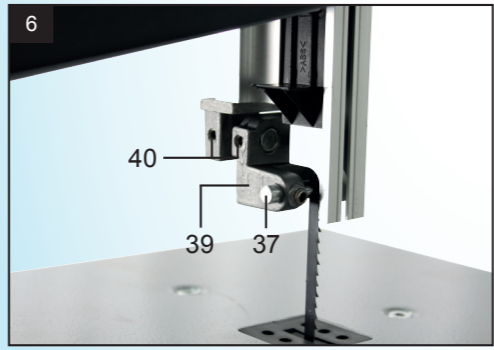
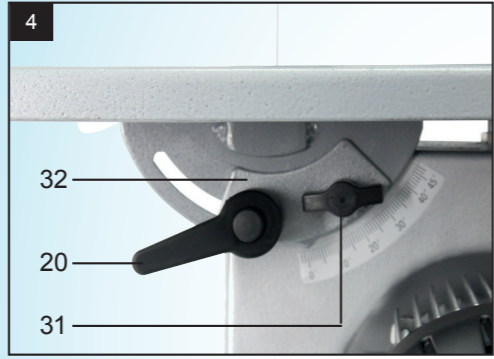
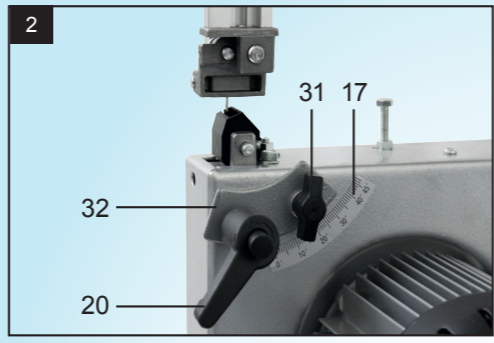
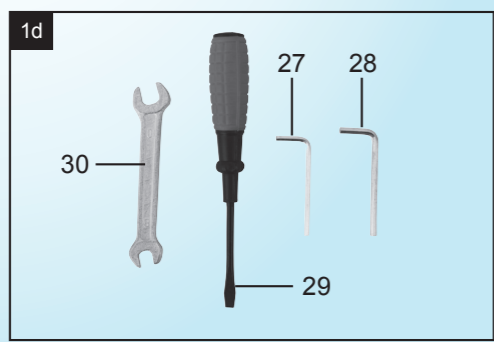
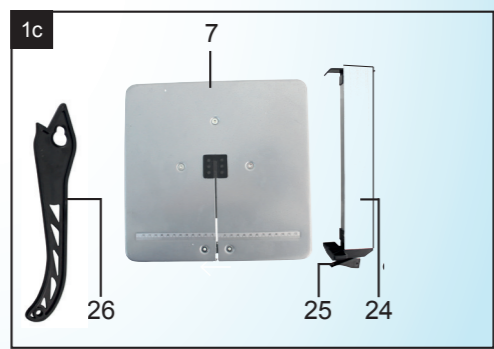
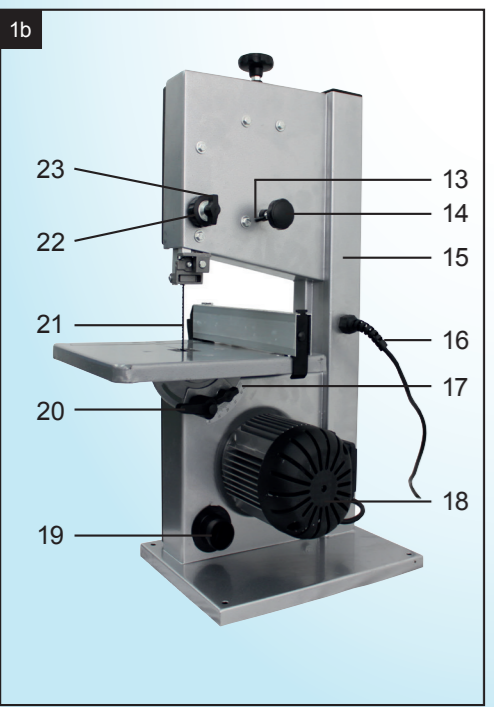
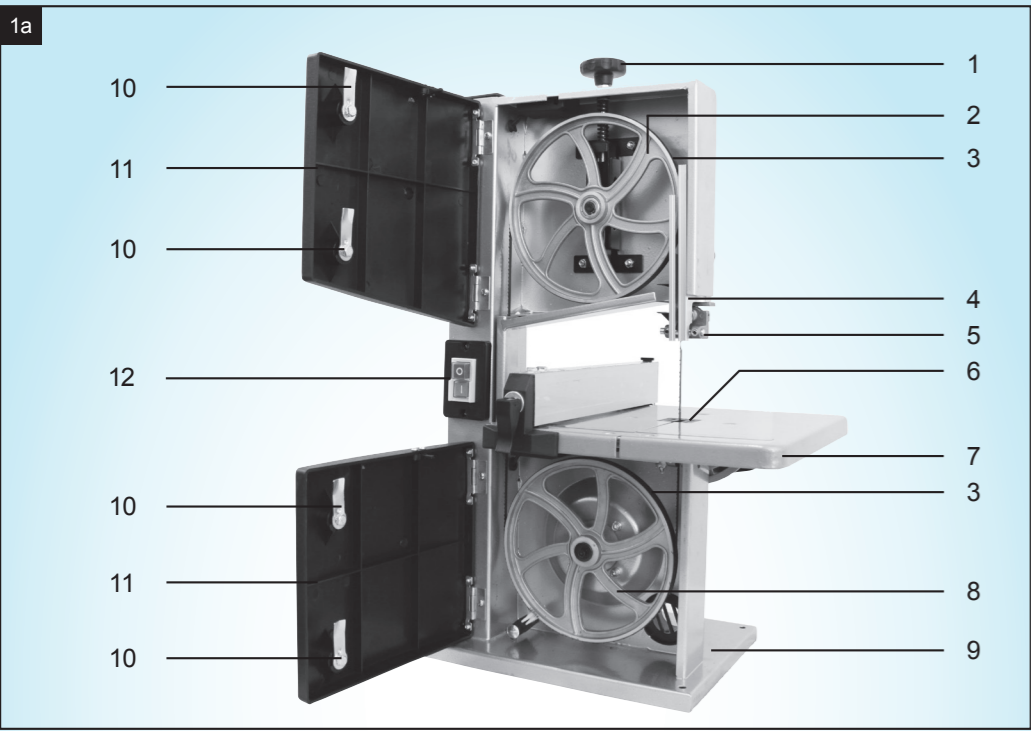

### Contents of Box

- 1 1 x Bandsaw
- 2 1 x Saw table
- 3 1 x Push stick
- 4 1 x Parallel stop
- 5 1 x Open-ended spanner 10 / 13 mm
- 6 1 x Allen key 3 mm
- 7 1 x Allen key 4 mm
- 8 1 x Screwdriver
- 9 1 x Instruction manual
- 10 1 x Warranty card

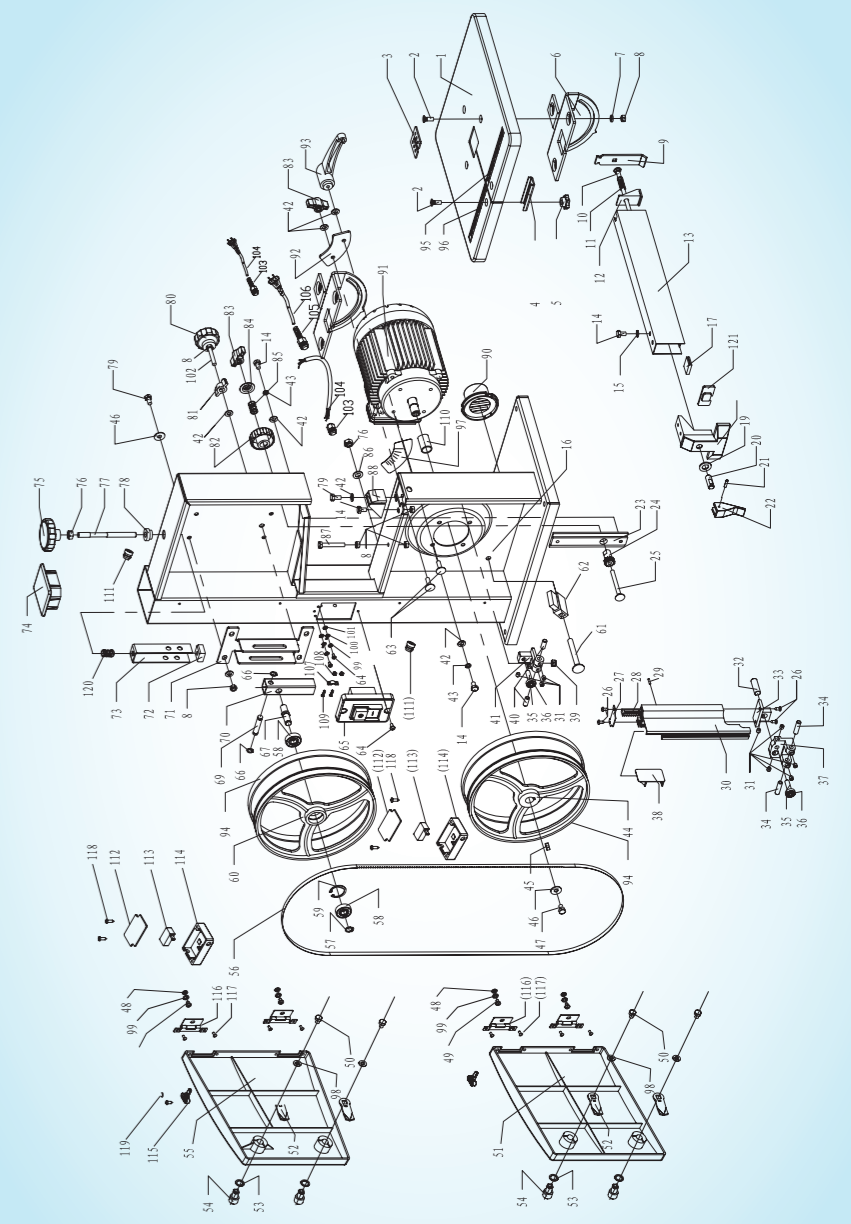

### AFTER SALES SUPPORT

support@schepach.com.au

AUS 1300 855 831

MODEL: HBS20 PRODUCT CODE: 60339

04/2018